

Passiv brandsikring af stålkonstruktioner



Vi gør forskellen



Skamol Group udvikler, producerer og distribuerer isoleringssystemer til en bred vifte af varmeintensive industrisektorer, samt til passiv brandsikring, pejseindsatser og skimmelforebyggelse.

Med vores systemer vil vi gerne hjælpe vores partnere og kunder med at skabe unik værdi og samtidig bidrage positivt til miljøet. Med vores unikke materialer kan vi nyde godt af mange fordele, herunder energibesparelser, større ydeevne, bedre arbejds- og levevilkår og endnu lavere CO2-emissioner.

Skamol blev grundlagt i Danmark i 1912 med det formål at udnytte de lokale forekomster af moler.

Siden er Skamol vokset til at være en førende global leverandør af tekniske isoleringssystemer, både til industriel og privat brug. Udover brugen af moler (diatomit) har vi udvidet vores produktsortiment til også at omfatte vermiculit og kalciumsilikat.

På forkant indenfor udviklingen af tekniske isoleringssystemer

Vi er blandt verdens førende indenfor forskning og systemudvikling samt nye teknikker og teknologier. Vores produktionsanlæg i Danmark, Polen og Rusland sikrer en kontinuerligt høj kvalitet – en egenskab, der ofte viser sig afgørende for vores kunder.

Vi tror på værdien af tæt samarbejde og dialog. Ligesom vi udvikler nye systemer med nye egenskaber, forbedrer og ændrer vi også eksisterende systemer. Når vi gør dette, tager vi specielt hensyn til vores kunders ønsker og markedets generelle krav.

Indhold

Brandsikring af stålkonstruktioner	4	30minutters brandmodstand: Lukkede profiler	17
Anvendelsesområder	5	60minutters brandmodstand: Lukkede profiler	18
Konstruktionsstål	6	90minutters brandmodstand: Lukkede profiler	19
Tykkelsen af SkamoStructure Board 250	6	120minutters brandmodstand: Lukkede profiler	20
SkamoStructure Board 250-størrelser	7	180minutters brandmodstand: Lukkede profiler	21
Montage	7	30minutters brandmodstand: Åbne profiler	22
3-sidet kvadratisk beklædning	8	60minutters brandmodstand: Åbne profiler	23
4-sidet kvadratisk beklædning	9	90minutters brandmodstand: Åbne profiler	24
3-sidet kvadratisk beklædning	10	120minutters brandmodstand: Åbne profiler	25
4-sidet kvadratisk beklædning	11	180minutters brandmodstand: Åbne profiler	26
4-sidet kvadratisk beklædning	12	SkamoStructure Board 250-beskyttede stålbjælker under trapezlofter	27
Datablad: SkamoStructure Board 250	13	30minutters brandmodstand: Stålprofiler under trapezlofter	28
Find den korrekte SkamoStructure Board 250-tykkelse	14	60minutters brandmodstand: Stålprofiler under trapezlofter	29
Eksempler på beregning af beklædning	15	90minutters brandmodstand: Stålprofiler under trapezlofter	30
Ap/V-forhold	16	120minutters brandmodstand: Stålprofiler under trapezlofter	31
		180minutters brandmodstand: Stålprofiler under trapezlofter	32
		Vores produktionsfaciliteter	33



Brandsikring af stålkonstruktioner

Det seriøse alternativ til konventionelle løsninger til passiv brandsikring af stålkonstruktioner

Skamol tilbyder nu et seriøst alternativ til traditionelle løsninger for passiv brandsikring af stålkonstruktioner.

Tidligere var de tilgængelige løsninger på markedet "cementbundne brandbeskyttelsesplader" eller brandhæmmende gipsplader til disse applikationer, og med SkamoStructure tilbyder Skamol nu et fuldgodt alternativ.

SkamoStructure Board 250 består af kalciumsilikat og leverer betydelige fordele i forhold til traditionelle løsninger.

Den lette håndtering

Især en faktor gør, at SkamoStructure skiller sig ud: Vores plader er meget lette. Det betyder, at materialet kan håndteres meget nemt. Påsætning er heller ikke noget problem – se side 7 for alle installationsmetoder, der kan bruges til at montere SkamoStructure.



Brandbeskyttelse af bærende bygningselementer er en afgørende faktor for at opfylde statens krav til brandbeskyttelse – og således sikre bygningens strukturelle stabilitet i tilfælde af brand. SkamoStructure er et letvægtsbyggesystem, som er den perfekte løsning til beskyttelse af stålkonstruktioner. Uanset om det drejer sig om åbne profiler, lukkede profiler eller søjler: SkamoStructure er ETA-certificeret.

Cementbundne brandbeskyttelsesplader.



SkamoStructure Board 250
Vægtreduktion på omkring 45 % i forhold til andre produkter på markedet.



Let i vægt

SkamoStructure Board 250 vejer kun 250kg/m³.



Hurtig montering

SkamoStructure er hurtig og nem at montere.



Brandbeskyttelse

SkamoStructure er et byggemateriale i klasse A1.

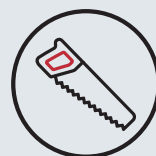

Let at håndtere

SkamoStructure kan håndteres uden behov for specielle værktøj.

Anvendelsesområder



Bjælke med åben profil.



Bjælke med lukket profil.

Alsidig og helt sikker – vigtige argumenter, der taler for SkamoStructure

SkamoStructure kan bruges til at beskytte alle bygningskonstruktionens relevante dele: Søjler, bjælker etc. kan alle beklædes, uanset om det er åbne eller lukkede profiler.

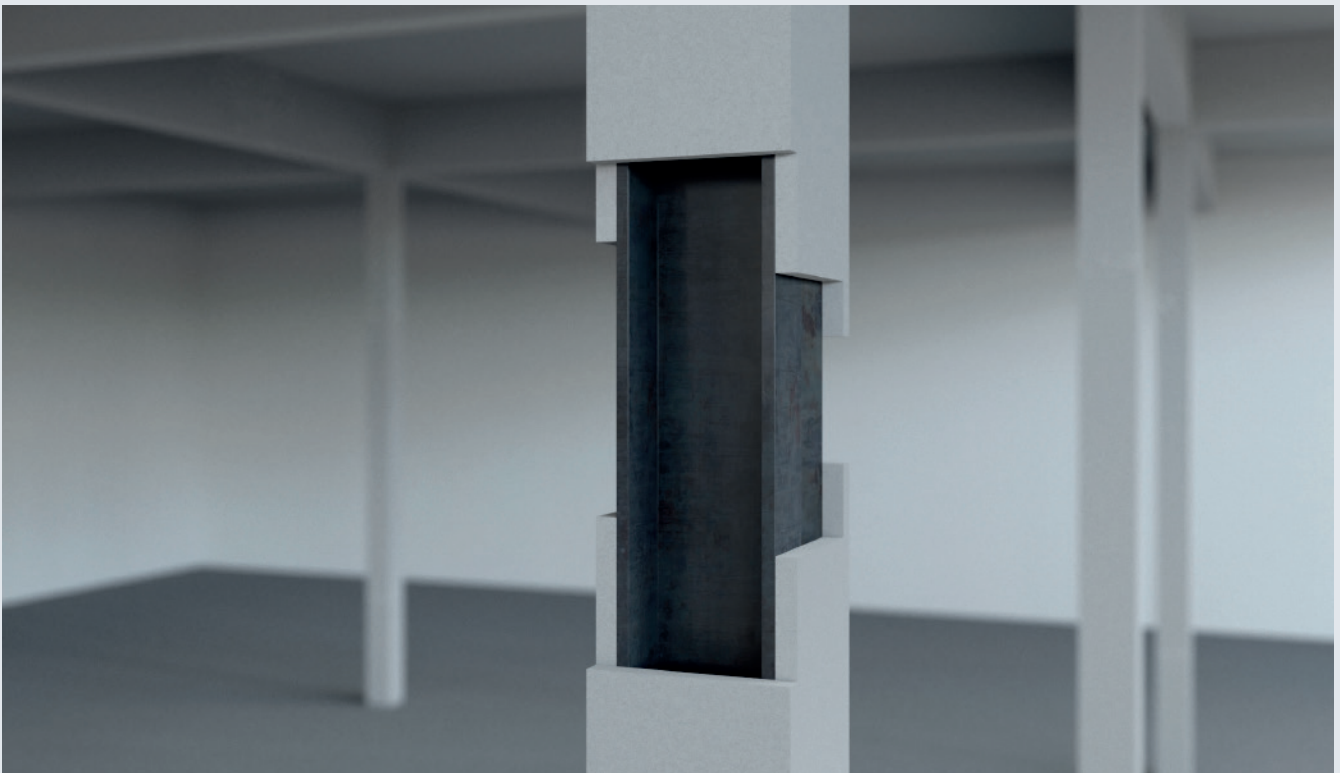

Søjle med åben profil.

Konstruktionsstål

Byggeforskrifter fastsætter, hvor længe nogle bygningselementer skal kunne modstå ild i tilfælde af brand. Den påkrævede brandbeskyttelse afhænger af følgende faktorer:

- Forudbestemt brandmodstandstid
- Stålelementets form og størrelse
- Andel af stålprofil, der udsættes for brand
- Type brandbeskyttelse anvendt

SkamoStructure-systemet er blevet testet i godkendte laboratorier i henhold til testproceduren til bestemmelse af bidraget af brandmodstandsdygtighed til bærende strukturelle komponenter (EN 13381-4).

Systemet er godkendt til bærende stålbjælker og søjler i overensstemmelse med ETA-11/00469. SkamoStructure Board bruges som firkantet beklædning til åbne og hule profiler for at beskytte stålet.

Tykkelsen af SkamoStructure Board 250

Sektionsfaktoren, den kritiske ståltemperatur og brandsikkerhedskravet skal tages i betragtning ved valg af pladetykkelse.

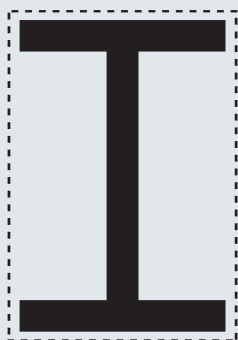

Boksbeskyttelse.

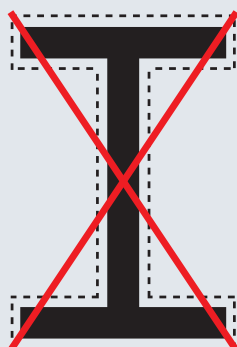

Profilbeskyttelse.

Sektionsfaktor

Sektionsfaktoren er en parameter, der anvendes til at bestemme stålkonstruktionskomponenters termiske opførsel. De grundlæggende faktorer er den hastighed, hvormed stålstøtterne og søjlerne opvarmes proportionalt med området, der er udsat for ild (A_p) og i omvendt forhold til stålprofilens volumen (V). Sektionsfaktoren beregnes ved hjælp af formlen A_p/V og måles m^{-1} , og værdien afhænger af, om arealet af stålbjælken, der udsættes for ild, er 3-sidet eller 4-sidet og den strukturelle komponenttykkelse. Sektionsfaktoren for stålprofiler kan leveres af stålleverandøren.

Kritisk ståltemperatur

Den kritiske ståltemperatur angiver, ved hvilken temperatur der kan opstå konstruktionssvagheder på grund af varmen. Den kritiske ståltemperatur kan leveres af stålleverandøren.

Brandbestandighedskrav

Byggeforskrifter fastsætter, hvor længe bygningselementer skal kunne modstå ild i tilfælde af brand.

SkamoStructure Board 250-størrelser

Produktnummer	Størrelse	Emballage	m ² / emballage	Stykke pr. palle
24160001	2.440 × 1.220 × 22mm	Stykke	2,98m ²	47
24160002	2.440 × 1.220 × 25mm	Stykke	2,98m ²	42
24160003	2.440 × 1.220 × 30mm	Stykke	2,98m ²	35
24160004	2.440 × 1.220 × 35mm	Stykke	2,98m ²	30
24160005	2.440 × 1.220 × 40mm	Stykke	2,98m ²	26
24160007	2.440 × 1.220 × 45mm	Stykke	2,98m ²	23
24160008	2.440 × 1.220 × 50mm	Stykke	2,98m ²	21
24160009	2.440 × 1.220 × 55mm	Stykke	2,98m ²	19
24160010	2.440 × 1.220 × 60mm	Stykke	2,98m ²	17

Montering

SkamoStructure Board fastgøres ved hjælp af skruer eller pistolsøm med en 30mm spændeskive, som angivet i tabellen.

SkamoStructure Board 250	Skruer til åbne og lukkede profiler		Pistolsøm med 30mm skiver til lukkede profiler	
	Tykkelse	Maksimal skruaefstand	Skruedimensioner	Maksimal pistolsømafstand
22	340mm	3,8 × 45mm	-	-
25	340mm	3,8 × 45mm	460mm	37mm
30	340mm	4,0 × 60mm:	460mm	42mm
35	340mm	4,0 × 70mm	460mm	47mm
40	340mm	5,0 × 80mm	460mm	52mm
45	340mm	5,0 × 90mm	460mm	57mm
50	340mm	5,0 × 90mm	460mm	62mm
55	340mm	5,0 × 100mm	-	-
60	340mm	5,0 × 110mm	-	-

Skamol anbefaler brugen af galvaniserede træ-/multimaterialeskruer og pistolsøm med dimensioner som angivet ovenfor i tabellen.

Til montering under trapezlofter anbefaler Skamol brug af gips-/spånpladeskruer jf. ovenstående montagetabel.

3-sidet kvadratisk beklædning



Alle dimensioner imm.

Placering af skruer i stål med åben profil – tresidet beskyttelse

For en mere stiv struktur bør pladens samlinger forskydes med ≥ 300 mm.

Strukturstøtterne skal savnes af med en minimumsbredde på 200mm og 1-2mm overskud i højden, så de kan presses ind mellem flangerne. Strukturstøtterne skal skæres med samme arktykkelse som forskallingen. Søjlerne skal fastgøres på hver samling og med en maksimal afstand på 1200mm mellem hinanden.

Se skrueoplysninger på side 7.

4-sidet kvadratisk beklædning

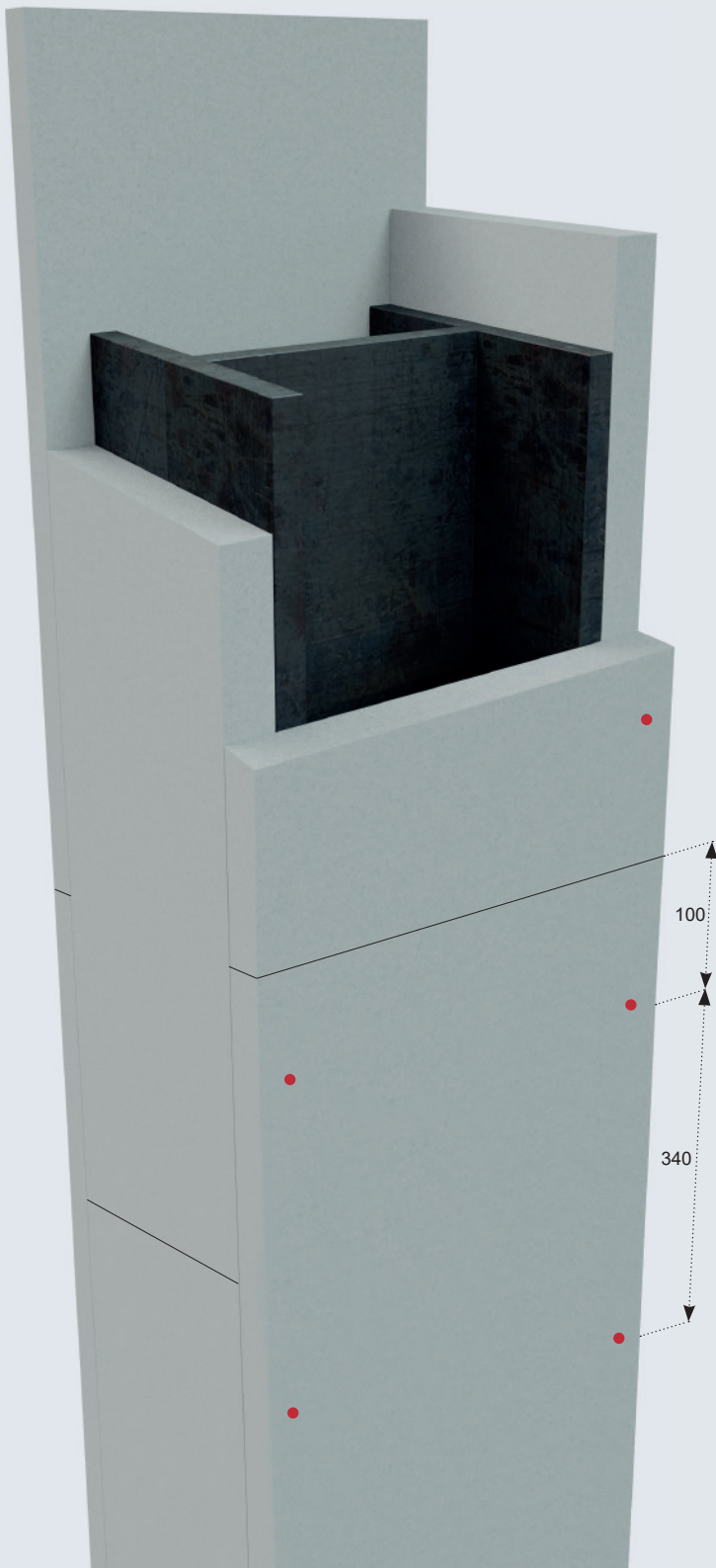

Alle dimensioner imm.

Placering af skruer i stål med åben profil – firesidet beskyttelse

For en mere stiv struktur bør pladens samlinger forskydes med $\geq 300\text{mm}$.

Se skrueoplysninger på side 7.

3-sidet kvadratisk beklædning

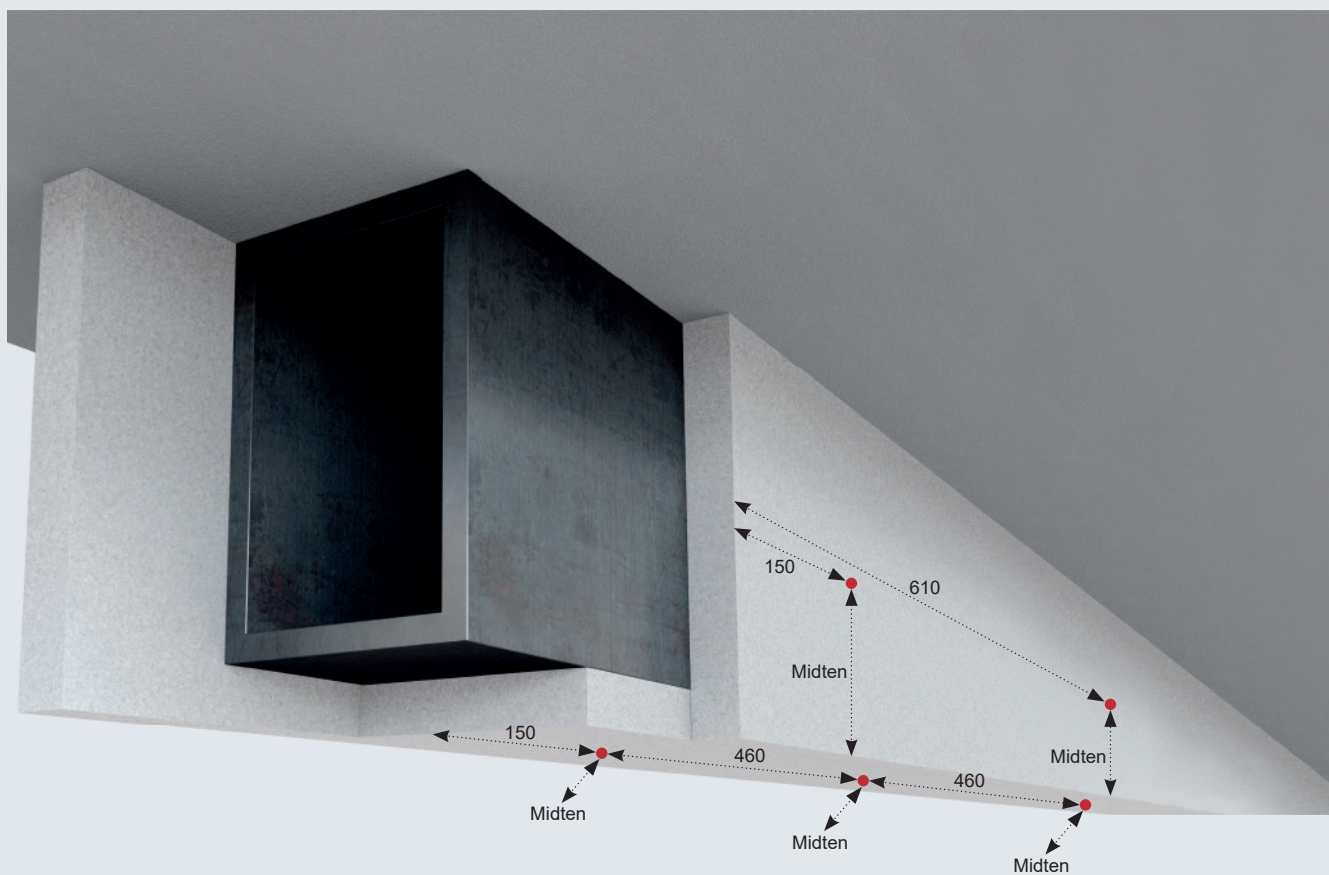

Alle dimensioner imm.

Placering af pistolsøm i stål med lukket profil – tresidet beskyttelse

For en mere stiv struktur bør pladens samlinger forskydes med ≥ 300 mm.

Se skruedata på side 7.

4-sidet kvadratisk beklædning

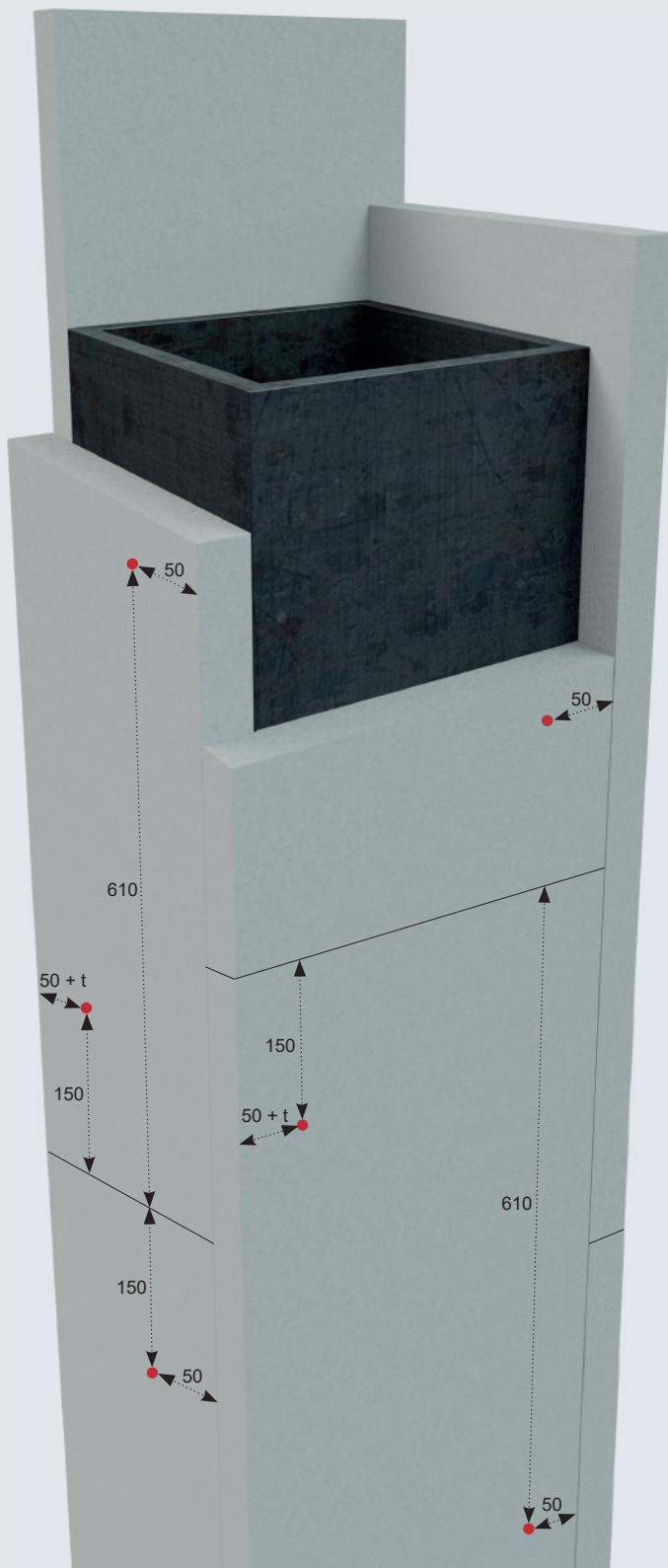

Alle dimensioner imm.

t = SkamoStructure Board 250 tykkelser.

Placering af pistolsøm i stål med lukket profil – firesidet beskyttelse

For en mere stiv struktur bør pladens samlinger forskydes med ≥ 300 mm.

Se skrueoplysninger på side 7.

4-sidet kvadratisk beklædning

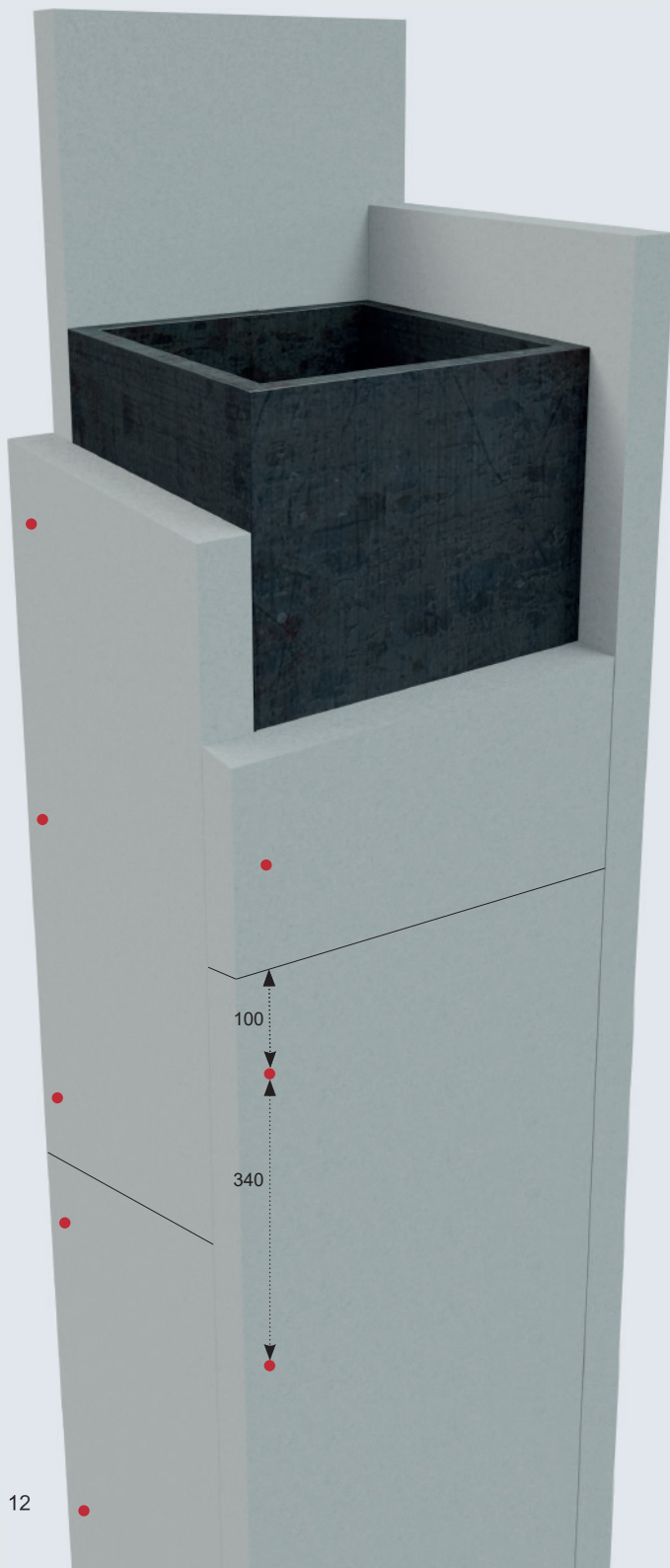

Alle dimensioner imm.

Placering af skruer i stål med lukket profil – firesidet beskyttelse

For en mere stiv struktur bør pladens samlinger forskydes med ≥ 300 mm.

Se skrueoplysninger på side 7.

Datablad: SkamoStructure Board 250

	Value	Unit
Non-combustibility tests (EN 13501-1:2007 + A1:2009)	Class A1	
Loadbearing steel beam and column protection (EN 13381-4)	Up to 180	minutes
Weather exposure category	Y (semi-exposure)	
Bulk density	250	kg/m ³
	16	lb/ft ³
Board weight (25mm thickness)	6.3	kg/m ²
	1.2	lb/ft ²
Cold crushing strength (DS/EN ISO 8895_2006)	2.8	MPa
	406	lb/in ²
Modulus of rupture (EN 993-6:1995)	1.3	MPa
	189	lb/in ²
Total porosity (EN 1094-4:1995)	90	%
Water content	2.5	%
Dimension stability under specified temp. and humidity conditions (EN 1604) at 23°C, 90% RH, 4 hours	0.0	%
Thermal conductivity (EN 12667), λ_{10}	0.073	W/(m×K)
	0.514	BTU/(ft ² ×h×°F/in)
Sound reduction index ($R_w(C;C_{tr})$)	Thickness	
	60mm	28 (-1;-3) dB
HS Tariff number (Harmonized Commodity Description and Coding System)	6806.90.00	
Colour	Grey	



Data are average results of tests conducted under standard procedures and are subject to variation. Data contained in this data sheet are supplied in good faith as a technical service and are subject to change without notice. Misprint and errors excepted. Revision number: 29.4.2022

Bestem den nødvendige SkamoStructure Board 250-tykkelse

Til dimensionering af brandbeskyttelse af stålkonstruktioner er det vigtigt at identificere stålprofilens kritiske ståltemperatur. Den kritiske ståltemperatur vises på projektmaterialet eller kan specificeres af projektkonsulenten.

Udover den kritiske ståltemperatur skal der også tages hensyn til A_p/V -forholdet (sektionsfaktoren) af den stålprofil, som skal beskyttes. Tabellerne på side 16 viser sektionsfaktoren for den mest almindelige stålprofil.

Når du kender stålprofilens A_p/V -forhold, kan du bestemme, hvilken SkamoStructure Board 250-tykkelse der skal anvendes ved en kritisk temperatur på 500°C i tabellen til højre.

Formel til beregning af A_p/V -forholdet for boksbeskyttelse:

A_p = indvendig omkreds af afskærmningen.
 A_p er summen af den indvendige omkreds af det mindste mulige rektangel eller firkant.

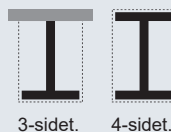

V = profilens tværsnitsareal.

Efter beregning af A_p/V -værdien skal boksbeskyttelsens sektionsfaktor altid rundes op.

Kritisk temperatur på 500°C (åben profil)

Tid (min)	A_p/V	Tykkelse (mm)
30	40-400	22
60	40-185	22
60	186-210	25
60	211-250	30
60	251-295	35
60	296-330	40
60	331-400	50
90	40-105	22
90	106-115	25
90	116-140	30
90	140-165	35
90	166-185	40
90	186-210	45
90	211-235	50
90	236-260	55
90	261-280	60
120	40-70	22
120	71-80	25
120	81-95	30
120	96-110	35
120	111-125	40
120	126-140	45
120	141-155	50
120	156-170	55
120	171-185	60
180	40	22
180	41-45	25
180	46-50	30
180	51-60	35
180	61-70	40
180	71-80	45
180	81-90	50
180	91-95	55
180	96-105	60

Eksempler på beregning af beklædning

Eksempler på beregning af tresidet beklædning

En stålprofil, IPE 200, skal være brandbeskyttet fra tre sider, og brandmodstanden skal være R60.

$$A_p = 2 \times 0,20\text{m} + 0,10\text{m} = 0,50\text{m}$$

$$V = 2.850\text{mm}^2 \approx 0,00285\text{m}^2$$

$$A_p/V = 0,50\text{m} / 0,00285\text{m}^2 \approx 176\text{m}^{-1}$$

Tykkelsen af SkamoStructure Board 250 ifølge tabel på side 14 = 22mm

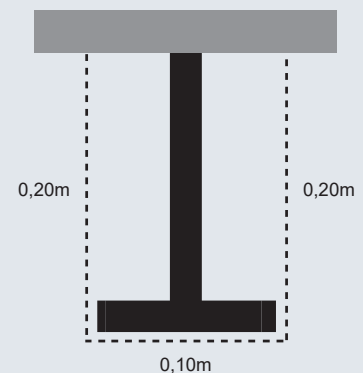

Eksempler på beregning af firesidet beklædning

En stålprofil, HE 120 A, skal være brandbeskyttet fra tre sider, og brandmodstanden skal være R90.

$$A_p = 2 \times 0,114\text{m} + 2 \times 0,120\text{m} = 0,468\text{m}$$

$$V = 2.534\text{mm}^2 \approx 0,002534\text{m}^2$$

$$A_p/V = 0,468\text{m} / 0,002534\text{m}^2 \approx 184\text{m}^{-1}$$

Tykkelsen af SkamoStructure Board 250 ifølge tabel på side 14 = 40mm

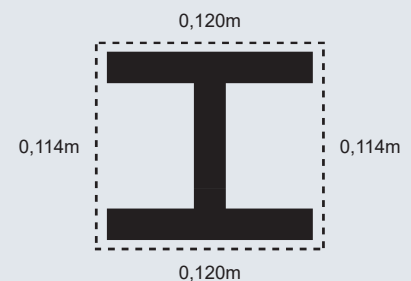

Ap/V-forhold

Ap/V-forholdet for den mest anvendte stålprofil er vist i tabellen nedenfor.

Kvadrat (mm)	3-sidet	4-sidet
100 × 100 × 4	198	264
100 × 100 × 5	161	214
100 × 100 × 6	136	181
100 × 100 × 8	105	139
100 × 100 × 10	86	115
120 × 120 × 5	159	212
120 × 120 × 6	134	178
120 × 120 × 8	103	137
120 × 120 × 10	84	112
140 × 140 × 5	158	210
140 × 140 × 6	133	177
140 × 140 × 8	101	135
140 × 140 × 10	83	111
150 × 150 × 5	157	210
150 × 150 × 6	132	176
150 × 150 × 8	101	134
150 × 150 × 10	82	110

Kvadrat (mm)	3-sidet	4-sidet
150 × 150 × 12,5	68	90
150 × 150 × 16	55	73
160 × 160 × 5	157	209
160 × 160 × 6	132	175
160 × 160 × 8	83	111
160 × 160 × 10	82	109
180 × 180 × 5	156	208
180 × 180 × 6,3	125	167
180 × 180 × 8	100	133
180 × 180 × 10	81	108
200 × 200 × 5	156	207
200 × 200 × 6,3	124	166
200 × 200 × 8	99	132
200 × 200 × 10	81	107
200 × 200 × 12,5	66	87
200 × 200 × 16	53	70

HEA	3-sidet	4-sidet	HEB	3-sidet	4-sidet	IPE	3-sidet	4-sidet	HEM	3-sidet	4-sidet
HE 100A	138	185	HE 100B	115	154	IPE 80	270	330	HE 100M	65	85
HE 120A	137	185	HE 120B	106	141	IPE 100	247	300	HE 120M	61	80
HE 140A	129	174	HE 140B	98	130	IPE 120	230	279	HE 140M	58	76
HE 160A	120	161	HE 160B	89	118	IPE 140	215	259	HE 160M	54	71
HE 180A	115	155	HE 180B	83	110	IPE 160	200	241	HE 180M	52	68
HE 200A	108	145	HE 200B	77	103	IPE 180	188	226	HE 200M	49	65
HE 220A	100	134	HE 220B	73	97	IPE 200	176	211	HE 220M	47	62
HE 240A	91	122	HE 240B	68	91	IPE 220	165	198	HE 240M	40	52
HE 260A	88	118	HE 260B	66	88	IPE 240	153	184	HE 260M	39	51
HE 280A	84	113	HE 280B	64	85	IPE 270	147	176	HE 280M	38	50
HE 300A	78	105	HE 300B	60	81	IPE 300	139	167	HE 300M	33	43
HE 320A	74	98	HE 320B	58	77	IPE 330	131	156	HE 320M	33	43
HE 340A	72	94	HE 340B	57	75	IPE 360	122	146	HE 340M	33	43
HE 360A	70	91	HE 360B	57	73	IPE 400	116	137			
HE 400A	68	87	HE 400B	56	71	IPE 450	110	130			
HE 450A	66	83	HE 450B	55	69	IPE 500	104	121			
HE 500A	65	80	HE 500B	55	67	IPE 550	98	113			
HE 550A	65	79	HE 550B	55	67	IPE 600	91	105			
HE 600A	65	79	HE 600B	55	67						
			HE 650B	55	66						

Kilde: Teknisk Ståbi

30minutters brandmodstand: Lukkede profiler

Design temp. Ap/V	350°C	400°C	450°C	500°C	550°C	600°C	650°C	700°C
60	25,0	25,0	25,0	25,0	25,0	25,0	25,0	25,0
65	25,0	25,0	25,0	25,0	25,0	25,0	25,0	25,0
70	25,0	25,0	25,0	25,0	25,0	25,0	25,0	25,0
75	25,0	25,0	25,0	25,0	25,0	25,0	25,0	25,0
80	25,0	25,0	25,0	25,0	25,0	25,0	25,0	25,0
85	25,0	25,0	25,0	25,0	25,0	25,0	25,0	25,0
90	25,0	25,0	25,0	25,0	25,0	25,0	25,0	25,0
95	25,0	25,0	25,0	25,0	25,0	25,0	25,0	25,0
100	25,0	25,0	25,0	25,0	25,0	25,0	25,0	25,0
105	25,0	25,0	25,0	25,0	25,0	25,0	25,0	25,0
110	25,0	25,0	25,0	25,0	25,0	25,0	25,0	25,0
115	25,0	25,0	25,0	25,0	25,0	25,0	25,0	25,0
120	25,0	25,0	25,0	25,0	25,0	25,0	25,0	25,0
125	25,0	25,0	25,0	25,0	25,0	25,0	25,0	25,0
130	25,0	25,0	25,0	25,0	25,0	25,0	25,0	25,0
135	25,0	25,0	25,0	25,0	25,0	25,0	25,0	25,0
140	25,0	25,0	25,0	25,0	25,0	25,0	25,0	25,0
145	25,0	25,0	25,0	25,0	25,0	25,0	25,0	25,0
150	25,0	25,0	25,0	25,0	25,0	25,0	25,0	25,0
155	25,0	25,0	25,0	25,0	25,0	25,0	25,0	25,0
160	25,0	25,0	25,0	25,0	25,0	25,0	25,0	25,0
165	25,0	25,0	25,0	25,0	25,0	25,0	25,0	25,0
170	25,0	25,0	25,0	25,0	25,0	25,0	25,0	25,0
175	25,0	25,0	25,0	25,0	25,0	25,0	25,0	25,0
180	25,0	25,0	25,0	25,0	25,0	25,0	25,0	25,0
185	25,0	25,0	25,0	25,0	25,0	25,0	25,0	25,0
190	25,0	25,0	25,0	25,0	25,0	25,0	25,0	25,0
195	25,0	25,0	25,0	25,0	25,0	25,0	25,0	25,0
200	25,0	25,0	25,0	25,0	25,0	25,0	25,0	25,0
205	25,0	25,0	25,0	25,0	25,0	25,0	25,0	25,0
210	25,0	25,0	25,0	25,0	25,0	25,0	25,0	25,0
215	25,0	25,0	25,0	25,0	25,0	25,0	25,0	25,0
220	25,0	25,0	25,0	25,0	25,0	25,0	25,0	25,0
225	25,0	25,0	25,0	25,0	25,0	25,0	25,0	25,0
230	25,0	25,0	25,0	25,0	25,0	25,0	25,0	25,0
235	25,0	25,0	25,0	25,0	25,0	25,0	25,0	25,0
240	30,0	25,0	25,0	25,0	25,0	25,0	25,0	25,0
245	30,0	25,0	25,0	25,0	25,0	25,0	25,0	25,0
250	30,0	25,0	25,0	25,0	25,0	25,0	25,0	25,0
255	30,0	25,0	25,0	25,0	25,0	25,0	25,0	25,0
260	30,0	25,0	25,0	25,0	25,0	25,0	25,0	25,0
265	30,0	25,0	25,0	25,0	25,0	25,0	25,0	25,0
270	30,0	25,0	25,0	25,0	25,0	25,0	25,0	25,0
275	30,0	25,0	25,0	25,0	25,0	25,0	25,0	25,0
280	30,0	25,0	25,0	25,0	25,0	25,0	25,0	25,0
285	30,0	25,0	25,0	25,0	25,0	25,0	25,0	25,0
290	30,0	25,0	25,0	25,0	25,0	25,0	25,0	25,0

60minutters brandmodstand: Lukkede profiler

Designtemp. Ap/V	350°C	400°C	450°C	500°C	550°C	600°C	650°C	700°C
60	25,0	25,0	25,0	25,0	25,0	25,0	25,0	25,0
65	25,0	25,0	25,0	25,0	25,0	25,0	25,0	25,0
70	30,0	25,0	25,0	25,0	25,0	25,0	25,0	25,0
75	30,0	25,0	25,0	25,0	25,0	25,0	25,0	25,0
80	30,0	25,0	25,0	25,0	25,0	25,0	25,0	25,0
85	30,0	25,0	25,0	25,0	25,0	25,0	25,0	25,0
90	30,0	25,0	25,0	25,0	25,0	25,0	25,0	25,0
95	30,0	25,0	25,0	25,0	25,0	25,0	25,0	25,0
100	30,0	30,0	25,0	25,0	25,0	25,0	25,0	25,0
105	30,0	30,0	25,0	25,0	25,0	25,0	25,0	25,0
110	30,0	30,0	25,0	25,0	25,0	25,0	25,0	25,0
115	35,0	30,0	25,0	25,0	25,0	25,0	25,0	25,0
120	35,0	30,0	25,0	25,0	25,0	25,0	25,0	25,0
125	35,0	30,0	25,0	25,0	25,0	25,0	25,0	25,0
130	35,0	30,0	25,0	25,0	25,0	25,0	25,0	25,0
135	35,0	30,0	30,0	25,0	25,0	25,0	25,0	25,0
140	35,0	30,0	30,0	25,0	25,0	25,0	25,0	25,0
145	35,0	30,0	30,0	25,0	25,0	25,0	25,0	25,0
150	35,0	35,0	30,0	25,0	25,0	25,0	25,0	25,0
155	35,0	35,0	30,0	25,0	25,0	25,0	25,0	25,0
160	40,0	35,0	30,0	25,0	25,0	25,0	25,0	25,0
165	40,0	35,0	30,0	25,0	25,0	25,0	25,0	25,0
170	40,0	35,0	30,0	25,0	25,0	25,0	25,0	25,0
175	40,0	35,0	30,0	25,0	25,0	25,0	25,0	25,0
180	40,0	35,0	30,0	25,0	25,0	25,0	25,0	25,0
185	40,0	35,0	30,0	25,0	25,0	25,0	25,0	25,0
190	40,0	35,0	30,0	30,0	25,0	25,0	25,0	25,0
195	40,0	35,0	30,0	30,0	25,0	25,0	25,0	25,0
200	40,0	35,0	30,0	30,0	25,0	25,0	25,0	25,0
205	45,0	35,0	35,0	30,0	25,0	25,0	25,0	25,0
210	45,0	40,0	35,0	30,0	25,0	25,0	25,0	25,0
215	45,0	40,0	35,0	30,0	25,0	25,0	25,0	25,0
220	45,0	40,0	35,0	30,0	25,0	25,0	25,0	25,0
225	45,0	40,0	35,0	30,0	25,0	25,0	25,0	25,0
230	45,0	40,0	35,0	30,0	25,0	25,0	25,0	25,0
235	45,0	40,0	35,0	30,0	25,0	25,0	25,0	25,0
240	45,0	40,0	35,0	30,0	25,0	25,0	25,0	25,0
245	45,0	40,0	35,0	30,0	25,0	25,0	25,0	25,0
250	45,0	40,0	35,0	30,0	25,0	25,0	25,0	25,0
255	45,0	40,0	35,0	30,0	25,0	25,0	25,0	25,0
260	50,0	40,0	35,0	30,0	25,0	25,0	25,0	25,0
265	50,0	40,0	35,0	30,0	25,0	25,0	25,0	25,0
270	50,0	40,0	35,0	30,0	25,0	25,0	25,0	25,0
275	50,0	40,0	35,0	30,0	30,0	25,0	25,0	25,0
280	50,0	40,0	35,0	30,0	30,0	25,0	25,0	25,0
285	50,0	45,0	35,0	30,0	30,0	25,0	25,0	25,0
290	50,0	45,0	35,0	30,0	30,0	25,0	25,0	25,0

90minutters brandmodstand: Lukkede profiler

Design temp. Ap/V	350°C	400°C	450°C	500°C	550°C	600°C	650°C	700°C
60	30,0	30,0	25,0	25,0	25,0	25,0	25,0	25,0
65	35,0	30,0	25,0	25,0	25,0	25,0	25,0	25,0
70	35,0	30,0	30,0	25,0	25,0	25,0	25,0	25,0
75	35,0	30,0	30,0	25,0	25,0	25,0	25,0	25,0
80	35,0	35,0	30,0	25,0	25,0	25,0	25,0	25,0
85	35,0	35,0	30,0	30,0	25,0	25,0	25,0	25,0
90	40,0	35,0	30,0	30,0	25,0	25,0	25,0	25,0
95	40,0	35,0	30,0	30,0	25,0	25,0	25,0	25,0
100	40,0	35,0	35,0	30,0	25,0	25,0	25,0	25,0
105	40,0	35,0	35,0	30,0	25,0	25,0	25,0	25,0
110	40,0	40,0	35,0	30,0	30,0	25,0	25,0	25,0
115	45,0	40,0	35,0	30,0	30,0	25,0	25,0	25,0
120	45,0	40,0	35,0	30,0	30,0	25,0	25,0	25,0
125	45,0	40,0	35,0	35,0	30,0	25,0	25,0	25,0
130	45,0	40,0	35,0	35,0	30,0	25,0	25,0	25,0
135	45,0	40,0	40,0	35,0	30,0	30,0	25,0	25,0
140	45,0	45,0	40,0	35,0	30,0	30,0	25,0	25,0
145	50,0	45,0	40,0	35,0	30,0	30,0	25,0	25,0
150	50,0	45,0	40,0	35,0	30,0	30,0	25,0	25,0
155	50,0	45,0	40,0	35,0	35,0	30,0	25,0	25,0
160	50,0	45,0	40,0	35,0	35,0	30,0	25,0	25,0
165	50,0	45,0	40,0	40,0	35,0	30,0	25,0	25,0
170	55,0	45,0	40,0	40,0	35,0	30,0	30,0	25,0
175	55,0	50,0	45,0	40,0	35,0	30,0	30,0	25,0
180	55,0	50,0	45,0	40,0	35,0	30,0	30,0	25,0
185		50,0	45,0	40,0	35,0	30,0	30,0	25,0
190		50,0	45,0	40,0	35,0	30,0	30,0	25,0
195		50,0	45,0	40,0	35,0	35,0	30,0	25,0
200		50,0	45,0	40,0	35,0	35,0	30,0	25,0
205		50,0	45,0	40,0	35,0	35,0	30,0	25,0
210		55,0	45,0	40,0	40,0	35,0	30,0	25,0
215		55,0	45,0	40,0	40,0	35,0	30,0	25,0
220		55,0	50,0	45,0	40,0	35,0	30,0	30,0
225		55,0	50,0	45,0	40,0	35,0	30,0	30,0
230			50,0	45,0	40,0	35,0	30,0	30,0
235			50,0	45,0	40,0	35,0	30,0	30,0
240			50,0	45,0	40,0	35,0	30,0	30,0
245			50,0	45,0	40,0	35,0	30,0	30,0
250			50,0	45,0	40,0	35,0	30,0	30,0
255			50,0	45,0	40,0	35,0	30,0	30,0
260			50,0	45,0	40,0	35,0	35,0	30,0
265			50,0	45,0	40,0	35,0	35,0	30,0
270			55,0	45,0	40,0	35,0	35,0	30,0
275			55,0	45,0	40,0	35,0	35,0	30,0
280			55,0	45,0	40,0	40,0	35,0	30,0
285			55,0	50,0	40,0	40,0	35,0	30,0
290			55,0	50,0	45,0	40,0	35,0	30,0

120minutters brandmodstand: Lukkede profiler

Designtemp. Ap/V	350°C	400°C	450°C	500°C	550°C	600°C	650°C	700°C
60	35,0	35,0	30,0	30,0	25,0	25,0	25,0	25,0
65	40,0	35,0	35,0	30,0	25,0	25,0	25,0	25,0
70	40,0	35,0	35,0	30,0	30,0	25,0	25,0	25,0
75	40,0	40,0	35,0	30,0	30,0	25,0	25,0	25,0
80	45,0	40,0	35,0	35,0	30,0	30,0	25,0	25,0
85	45,0	40,0	40,0	35,0	30,0	30,0	25,0	25,0
90	45,0	40,0	40,0	35,0	35,0	30,0	25,0	25,0
95	45,0	45,0	40,0	35,0	35,0	30,0	30,0	25,0
100	50,0	45,0	40,0	40,0	35,0	30,0	30,0	25,0
105	50,0	45,0	40,0	40,0	35,0	30,0	30,0	25,0
110	50,0	45,0	45,0	40,0	35,0	35,0	30,0	25,0
115	50,0	50,0	45,0	40,0	35,0	35,0	30,0	30,0
120	55,0	50,0	45,0	40,0	40,0	35,0	30,0	30,0
125		50,0	45,0	40,0	40,0	35,0	30,0	30,0
130		50,0	45,0	45,0	40,0	35,0	35,0	30,0
135		55,0	50,0	45,0	40,0	35,0	35,0	30,0
140		55,0	50,0	45,0	40,0	35,0	35,0	30,0
145		55,0	50,0	45,0	40,0	40,0	35,0	30,0
150			50,0	45,0	45,0	40,0	35,0	30,0
155			50,0	45,0	45,0	40,0	35,0	35,0
160			55,0	50,0	45,0	40,0	35,0	35,0
165			55,0	50,0	45,0	40,0	35,0	35,0
170			55,0	50,0	45,0	40,0	40,0	35,0
175				50,0	45,0	40,0	40,0	35,0
180				50,0	45,0	40,0	40,0	35,0
185				50,0	45,0	45,0	40,0	35,0
190				50,0	50,0	45,0	40,0	35,0
195				55,0	50,0	45,0	40,0	35,0
200				55,0	50,0	45,0	40,0	35,0
205				55,0	50,0	45,0	40,0	35,0
210					50,0	45,0	40,0	35,0
215					50,0	45,0	40,0	40,0
220					50,0	45,0	40,0	40,0
225					50,0	45,0	40,0	40,0
230					50,0	45,0	45,0	40,0
235					50,0	45,0	45,0	40,0
240					55,0	50,0	45,0	40,0
245					55,0	50,0	45,0	40,0
250					55,0	50,0	45,0	40,0
255					55,0	50,0	45,0	40,0
260					55,0	50,0	45,0	40,0
265						50,0	45,0	40,0
270						50,0	45,0	40,0
275						50,0	45,0	40,0
280						50,0	45,0	40,0
285						50,0	45,0	40,0
290						50,0	45,0	40,0

180minutters brandmodstand: Lukkede profiler

Designtemp. Ap/V	350°C	400°C	450°C	500°C	550°C	600°C	650°C	700°C
60	50,0	45,0	40,0	40,0	35,0	35,0	30,0	30,0
65	50,0	45,0	45,0	40,0	40,0	35,0	35,0	30,0
70	50,0	50,0	45,0	45,0	40,0	35,0	35,0	30,0
75	55,0	50,0	50,0	45,0	40,0	40,0	35,0	35,0
80		55,0	50,0	45,0	45,0	40,0	40,0	35,0
85			50,0	50,0	45,0	40,0	40,0	35,0
90			55,0	50,0	45,0	45,0	40,0	40,0
95				50,0	50,0	45,0	40,0	40,0
100				55,0	50,0	45,0	45,0	40,0
105					50,0	50,0	45,0	40,0
110					55,0	50,0	45,0	40,0
115					55,0	50,0	45,0	45,0
120						50,0	50,0	45,0
125						55,0	50,0	45,0
130						55,0	50,0	45,0
135							50,0	45,0
140							50,0	50,0
145							55,0	50,0
150							55,0	50,0
155							55,0	50,0
160								50,0
165								50,0
170								55,0
175								55,0
180								55,0
185								
190								
195								
200								
205								
210								
215								
220								
225								
230								
235								
240								
245								
250								
255								
260								
265								
270								
275								
280								
285								
290								

30minutters brandmodstand: Åbne profiler

Designtemp. Ap/V	350°C	400°C	450°C	500°C	550°C	600°C	650°C
40	22,0	22,0	22,0	22,0	22,0	22,0	22,0
45	22,0	22,0	22,0	22,0	22,0	22,0	22,0
50	22,0	22,0	22,0	22,0	22,0	22,0	22,0
55	22,0	22,0	22,0	22,0	22,0	22,0	22,0
60	22,0	22,0	22,0	22,0	22,0	22,0	22,0
65	22,0	22,0	22,0	22,0	22,0	22,0	22,0
70	22,0	22,0	22,0	22,0	22,0	22,0	22,0
75	22,0	22,0	22,0	22,0	22,0	22,0	22,0
80	22,0	22,0	22,0	22,0	22,0	22,0	22,0
85	22,0	22,0	22,0	22,0	22,0	22,0	22,0
90	22,0	22,0	22,0	22,0	22,0	22,0	22,0
95	22,0	22,0	22,0	22,0	22,0	22,0	22,0
100	22,0	22,0	22,0	22,0	22,0	22,0	22,0
105	22,0	22,0	22,0	22,0	22,0	22,0	22,0
110	22,0	22,0	22,0	22,0	22,0	22,0	22,0
115	22,0	22,0	22,0	22,0	22,0	22,0	22,0
120	22,0	22,0	22,0	22,0	22,0	22,0	22,0
125	22,0	22,0	22,0	22,0	22,0	22,0	22,0
130	22,0	22,0	22,0	22,0	22,0	22,0	22,0
135	22,0	22,0	22,0	22,0	22,0	22,0	22,0
140	22,0	22,0	22,0	22,0	22,0	22,0	22,0
145	22,0	22,0	22,0	22,0	22,0	22,0	22,0
150	22,0	22,0	22,0	22,0	22,0	22,0	22,0
155	22,0	22,0	22,0	22,0	22,0	22,0	22,0
160	22,0	22,0	22,0	22,0	22,0	22,0	22,0
165	22,0	22,0	22,0	22,0	22,0	22,0	22,0
170	22,0	22,0	22,0	22,0	22,0	22,0	22,0
175	22,0	22,0	22,0	22,0	22,0	22,0	22,0
180	22,0	22,0	22,0	22,0	22,0	22,0	22,0
185	22,0	22,0	22,0	22,0	22,0	22,0	22,0
190	22,0	22,0	22,0	22,0	22,0	22,0	22,0
195	22,0	22,0	22,0	22,0	22,0	22,0	22,0
200	22,0	22,0	22,0	22,0	22,0	22,0	22,0
205	22,0	22,0	22,0	22,0	22,0	22,0	22,0
210	22,0	22,0	22,0	22,0	22,0	22,0	22,0
215	22,0	22,0	22,0	22,0	22,0	22,0	22,0
220	22,0	22,0	22,0	22,0	22,0	22,0	22,0
225	22,0	22,0	22,0	22,0	22,0	22,0	22,0
230	22,0	22,0	22,0	22,0	22,0	22,0	22,0
235	22,0	22,0	22,0	22,0	22,0	22,0	22,0
240	22,0	22,0	22,0	22,0	22,0	22,0	22,0
245	22,0	22,0	22,0	22,0	22,0	22,0	22,0
250	22,0	22,0	22,0	22,0	22,0	22,0	22,0
255	22,0	22,0	22,0	22,0	22,0	22,0	22,0
260	22,0	22,0	22,0	22,0	22,0	22,0	22,0
265	22,0	22,0	22,0	22,0	22,0	22,0	22,0
270	22,0	22,0	22,0	22,0	22,0	22,0	22,0
275	22,0	22,0	22,0	22,0	22,0	22,0	22,0
280	22,0	22,0	22,0	22,0	22,0	22,0	22,0
285	22,0	22,0	22,0	22,0	22,0	22,0	22,0
290	22,0	22,0	22,0	22,0	22,0	22,0	22,0
295	22,0	22,0	22,0	22,0	22,0	22,0	22,0
300	22,0	22,0	22,0	22,0	22,0	22,0	22,0
330	22,0	22,0	22,0	22,0	22,0	22,0	22,0
400	30,0	25,0	22,0	22,0	22,0	22,0	22,0

60minutters brandmodstand: Åbne profiler

Designtemp. Ap/V	350°C	400°C	450°C	500°C	550°C	600°C	650°C
40	22,0	22,0	22,0	22,0	22,0	22,0	22,0
45	22,0	22,0	22,0	22,0	22,0	22,0	22,0
50	22,0	22,0	22,0	22,0	22,0	22,0	22,0
55	22,0	22,0	22,0	22,0	22,0	22,0	22,0
60	22,0	22,0	22,0	22,0	22,0	22,0	22,0
65	22,0	22,0	22,0	22,0	22,0	22,0	22,0
70	22,0	22,0	22,0	22,0	22,0	22,0	22,0
75	22,0	22,0	22,0	22,0	22,0	22,0	22,0
80	22,0	22,0	22,0	22,0	22,0	22,0	22,0
85	22,0	22,0	22,0	22,0	22,0	22,0	22,0
90	22,0	22,0	22,0	22,0	22,0	22,0	22,0
95	22,0	22,0	22,0	22,0	22,0	22,0	22,0
100	22,0	22,0	22,0	22,0	22,0	22,0	22,0
105	22,0	22,0	22,0	22,0	22,0	22,0	22,0
110	22,0	22,0	22,0	22,0	22,0	22,0	22,0
115	22,0	22,0	22,0	22,0	22,0	22,0	22,0
120	22,0	22,0	22,0	22,0	22,0	22,0	22,0
125	25,0	22,0	22,0	22,0	22,0	22,0	22,0
130	25,0	22,0	22,0	22,0	22,0	22,0	22,0
135	25,0	22,0	22,0	22,0	22,0	22,0	22,0
140	25,0	22,0	22,0	22,0	22,0	22,0	22,0
145	30,0	25,0	22,0	22,0	22,0	22,0	22,0
150	30,0	25,0	22,0	22,0	22,0	22,0	22,0
155	30,0	25,0	22,0	22,0	22,0	22,0	22,0
160	30,0	25,0	22,0	22,0	22,0	22,0	22,0
165	30,0	30,0	25,0	22,0	22,0	22,0	22,0
170	35,0	30,0	25,0	22,0	22,0	22,0	22,0
175	35,0	30,0	25,0	22,0	22,0	22,0	22,0
180	35,0	30,0	25,0	22,0	22,0	22,0	22,0
185	35,0	30,0	25,0	22,0	22,0	22,0	22,0
190	35,0	30,0	30,0	25,0	22,0	22,0	22,0
195	35,0	30,0	30,0	25,0	22,0	22,0	22,0
200	40,0	35,0	30,0	25,0	22,0	22,0	22,0
205	40,0	35,0	30,0	25,0	22,0	22,0	22,0
210	40,0	35,0	30,0	25,0	22,0	22,0	22,0
215	40,0	35,0	30,0	30,0	25,0	22,0	22,0
220	40,0	35,0	30,0	30,0	25,0	22,0	22,0
225	45,0	35,0	35,0	30,0	25,0	22,0	22,0
230	45,0	40,0	35,0	30,0	25,0	22,0	22,0
235	45,0	40,0	35,0	30,0	25,0	22,0	22,0
240	45,0	40,0	35,0	30,0	30,0	25,0	22,0
245	45,0	40,0	35,0	30,0	30,0	25,0	22,0
250	45,0	40,0	35,0	30,0	30,0	25,0	22,0
255	50,0	40,0	35,0	35,0	30,0	25,0	22,0
260	50,0	40,0	35,0	35,0	30,0	25,0	22,0
265	50,0	45,0	40,0	35,0	30,0	25,0	25,0
270	50,0	45,0	40,0	35,0	30,0	30,0	25,0
275	50,0	45,0	40,0	35,0	30,0	30,0	25,0
280	55,0	45,0	40,0	35,0	30,0	30,0	25,0
285	55,0	45,0	40,0	35,0	30,0	30,0	25,0
290	55,0	45,0	40,0	35,0	35,0	30,0	25,0
295	55,0	50,0	40,0	35,0	35,0	30,0	25,0
300	55,0	50,0	45,0	40,0	35,0	30,0	25,0
330	60,0	55,0	45,0	40,0	35,0	35,0	30,0
400			55,0	50,0	45,0	40,0	35,0

90minutters brandmodstand: Åbne profiler

Designtemp. Ap/V	350°C	400°C	450°C	500°C	550°C	600°C	650°C
40	22,0	22,0	22,0	22,0	22,0	22,0	22,0
45	22,0	22,0	22,0	22,0	22,0	22,0	22,0
50	22,0	22,0	22,0	22,0	22,0	22,0	22,0
55	22,0	22,0	22,0	22,0	22,0	22,0	22,0
60	22,0	22,0	22,0	22,0	22,0	22,0	22,0
65	22,0	22,0	22,0	22,0	22,0	22,0	22,0
70	22,0	22,0	22,0	22,0	22,0	22,0	22,0
75	25,0	22,0	22,0	22,0	22,0	22,0	22,0
80	25,0	22,0	22,0	22,0	22,0	22,0	22,0
85	30,0	25,0	22,0	22,0	22,0	22,0	22,0
90	30,0	25,0	22,0	22,0	22,0	22,0	22,0
95	30,0	30,0	25,0	22,0	22,0	22,0	22,0
100	35,0	30,0	25,0	22,0	22,0	22,0	22,0
105	35,0	30,0	25,0	22,0	22,0	22,0	22,0
110	35,0	30,0	30,0	25,0	22,0	22,0	22,0
115	40,0	35,0	30,0	25,0	22,0	22,0	22,0
120	40,0	35,0	30,0	30,0	25,0	22,0	22,0
125	40,0	35,0	30,0	30,0	25,0	22,0	22,0
130	45,0	40,0	35,0	30,0	25,0	22,0	22,0
135	45,0	40,0	35,0	30,0	30,0	25,0	22,0
140	45,0	40,0	35,0	30,0	30,0	25,0	22,0
145	50,0	40,0	35,0	35,0	30,0	25,0	22,0
150	50,0	45,0	40,0	35,0	30,0	30,0	25,0
155	50,0	45,0	40,0	35,0	30,0	30,0	25,0
160	55,0	45,0	40,0	35,0	30,0	30,0	25,0
165	55,0	45,0	40,0	35,0	35,0	30,0	25,0
170	55,0	50,0	45,0	40,0	35,0	30,0	30,0
175	60,0	50,0	45,0	40,0	35,0	30,0	30,0
180	60,0	50,0	45,0	40,0	35,0	35,0	30,0
185	60,0	55,0	45,0	40,0	35,0	35,0	30,0
190		55,0	50,0	45,0	40,0	35,0	30,0
195		55,0	50,0	45,0	40,0	35,0	30,0
200		55,0	50,0	45,0	40,0	35,0	35,0
205		60,0	50,0	45,0	40,0	35,0	35,0
210		60,0	55,0	45,0	40,0	40,0	35,0
215		60,0	55,0	50,0	45,0	40,0	35,0
220			55,0	50,0	45,0	40,0	35,0
225			55,0	50,0	45,0	40,0	35,0
230			55,0	50,0	45,0	40,0	35,0
235			60,0	50,0	45,0	40,0	40,0
240			60,0	55,0	50,0	45,0	40,0
245			60,0	55,0	50,0	45,0	40,0
250			60,0	55,0	50,0	45,0	40,0
255				55,0	50,0	45,0	40,0
260				55,0	50,0	45,0	40,0
265				60,0	50,0	45,0	45,0
270				60,0	55,0	50,0	45,0
275				60,0	55,0	50,0	45,0
280				60,0	55,0	50,0	45,0
285					55,0	50,0	45,0
290					55,0	50,0	45,0
295					60,0	50,0	45,0
300					60,0	55,0	50,0
330						60,0	50,0
400							

120minutters brandmodstand: Åbne profiler

Designtemp. Ap/V	350°C	400°C	450°C	500°C	550°C	600°C	650°C
40	22,0	22,0	22,0	22,0	22,0	22,0	22,0
45	22,0	22,0	22,0	22,0	22,0	22,0	22,0
50	25,0	22,0	22,0	22,0	22,0	22,0	22,0
55	30,0	22,0	22,0	22,0	22,0	22,0	22,0
60	30,0	25,0	22,0	22,0	22,0	22,0	22,0
65	35,0	30,0	25,0	22,0	22,0	22,0	22,0
70	35,0	30,0	25,0	22,0	22,0	22,0	22,0
75	40,0	35,0	30,0	25,0	22,0	22,0	22,0
80	40,0	35,0	30,0	25,0	25,0	22,0	22,0
85	40,0	35,0	35,0	30,0	25,0	22,0	22,0
90	45,0	40,0	35,0	30,0	30,0	25,0	22,0
95	45,0	40,0	35,0	30,0	30,0	25,0	22,0
100	50,0	45,0	40,0	35,0	30,0	30,0	25,0
105	50,0	45,0	40,0	35,0	30,0	30,0	25,0
110	55,0	45,0	40,0	35,0	35,0	30,0	25,0
115	55,0	50,0	45,0	40,0	35,0	30,0	30,0
120	60,0	50,0	45,0	40,0	35,0	35,0	30,0
125	60,0	55,0	45,0	40,0	40,0	35,0	30,0
130		55,0	50,0	45,0	40,0	35,0	30,0
135		55,0	50,0	45,0	40,0	35,0	35,0
140		60,0	50,0	45,0	40,0	40,0	35,0
145		60,0	55,0	50,0	45,0	40,0	35,0
150			55,0	50,0	45,0	40,0	35,0
155			60,0	50,0	45,0	40,0	40,0
160			60,0	55,0	50,0	45,0	40,0
165			60,0	55,0	50,0	45,0	40,0
170				55,0	50,0	45,0	40,0
175				60,0	50,0	45,0	40,0
180				60,0	55,0	50,0	45,0
185				60,0	55,0	50,0	45,0
190					55,0	50,0	45,0
195					60,0	50,0	45,0
200					60,0	55,0	50,0
205					60,0	55,0	50,0
210					60,0	55,0	50,0
215						55,0	50,0
220						60,0	55,0
225						60,0	55,0
230						60,0	55,0
235						60,0	55,0
240							55,0
245							60,0
250							60,0
255							60,0
260							60,0
265							
270							
275							
280							
285							
290							
295							
300							
330							
400							

180minutters brandmodstand: Åbne profiler

Designtemp. Ap/V	350°C	400°C	450°C	500°C	550°C	600°C	650°C
40	35,0	30,0	25,0	22,0	22,0	22,0	22,0
45	40,0	35,0	30,0	25,0	22,0	22,0	22,0
50	45,0	35,0	35,0	30,0	25,0	22,0	22,0
55	45,0	40,0	35,0	35,0	30,0	25,0	22,0
60	50,0	45,0	40,0	35,0	30,0	30,0	25,0
65	55,0	50,0	45,0	40,0	35,0	30,0	30,0
70	60,0	50,0	45,0	40,0	35,0	35,0	30,0
75		55,0	50,0	45,0	40,0	35,0	30,0
80		60,0	50,0	45,0	40,0	40,0	35,0
85			55,0	50,0	45,0	40,0	35,0
90			60,0	50,0	45,0	40,0	40,0
95			60,0	55,0	50,0	45,0	40,0
100				60,0	50,0	45,0	45,0
105				60,0	55,0	50,0	45,0
110					55,0	50,0	45,0
115					60,0	55,0	50,0
120					60,0	55,0	50,0
125						60,0	55,0
130						60,0	55,0
135							55,0
140							60,0
145							60,0
150							
155							
160							
165							
170							
175							
180							
185							
190							
195							
200							
205							
210							
215							
220							
225							
230							
235							
240							
245							
250							
255							
260							
265							
270							
275							
280							
285							
290							
295							
300							
330							
400							

SkamoStructure Board 250-beskyttede stålprofiler under trapezlofter

Test DK R30 til R180

- Sektionsfaktoren for bjælken skal beregnes som eksponeret for brand på 4 sider.
- Kontaktfladen mellem bjælkens øverste flange og trapezloftet skal være 40% eller lavere end det samlede overfladeareal af bjælken.
- Tykkelsen af SkamoStructure Board 250 er angivet i de vedlagte designtabeller og skal være den samme for siderne og det øverste blokeringsstykke, der er placeret mellem trapezprofilen.
- Trapezloftet skal fyldes med et ikke-brændbart materiale, f.eks. mineraluld og må ikke indeholde lufthuller.
- Tykkelsen på stålet i trapezloftet skal være 1,2mm eller mindre.
- Alle mellemrum mellem SkamoStructure Board 250 og trapezloftet skal være fyldt med brandtætningsmasse.
- Tegninger af konstruktionen med de vurderede ændringer er knyttet til denne test.
- Evalueringen er kun gyldig for kravene i teststandard ENV 13381-4: 2002.
- Alle andre detaljer skal konstrueres som beskrevet i testrapport PH13583_rev1.

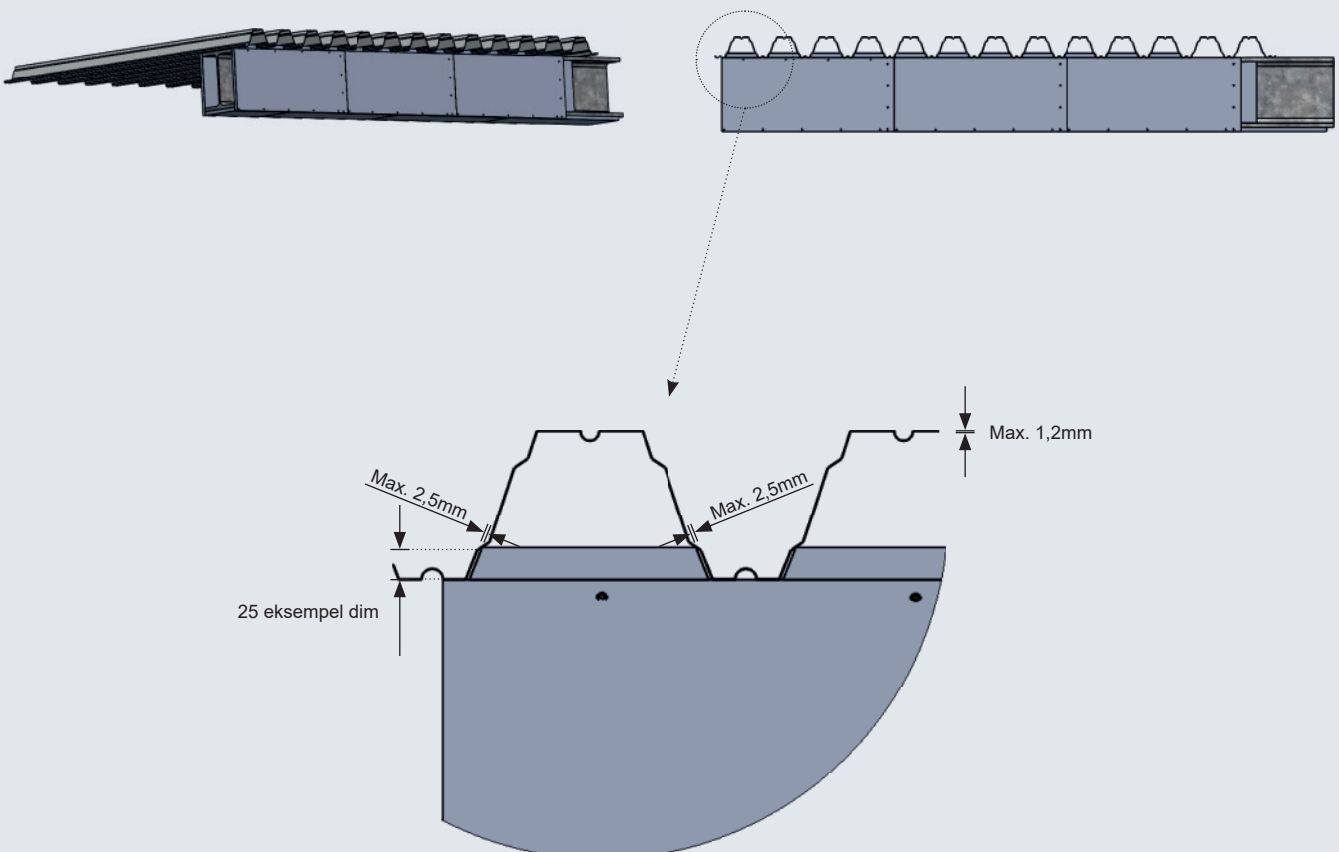

30minutters brandmodstand: Stålprofiler under trapezlofter

Designtemp. Ap/V	350°C	400°C	450°C	500°C	550°C	600°C	650°C
40	20	20	20	20	20	20	20
45	20	20	20	20	20	20	20
50	20	20	20	20	20	20	20
55	20	20	20	20	20	20	20
60	20	20	20	20	20	20	20
65	20	20	20	20	20	20	20
70	20	20	20	20	20	20	20
75	20	20	20	20	20	20	20
80	20	20	20	20	20	20	20
85	20	20	20	20	20	20	20
90	20	20	20	20	20	20	20
95	20	20	20	20	20	20	20
100	20	20	20	20	20	20	20
105	20	20	20	20	20	20	20
110	20	20	20	20	20	20	20
115	20	20	20	20	20	20	20
120	20	20	20	20	20	20	20
125	20	20	20	20	20	20	20
130	20	20	20	20	20	20	20
135	20	20	20	20	20	20	20
140	20	20	20	20	20	20	20
145	20	20	20	20	20	20	20
150	20	20	20	20	20	20	20
155	20	20	20	20	20	20	20
160	20	20	20	20	20	20	20
165	20	20	20	20	20	20	20
170	20	20	20	20	20	20	20
175	20	20	20	20	20	20	20
180	20	20	20	20	20	20	20
185	20	20	20	20	20	20	20
190	20	20	20	20	20	20	20
195	20	20	20	20	20	20	20
200	20	20	20	20	20	20	20
205	20	20	20	20	20	20	20
210	20	20	20	20	20	20	20
215	20	20	20	20	20	20	20
220	20	20	20	20	20	20	20
225	20	20	20	20	20	20	20
230	20	20	20	20	20	20	20
235	20	20	20	20	20	20	20
240	20	20	20	20	20	20	20
245	20	20	20	20	20	20	20
250	20	20	20	20	20	20	20
255	20	20	20	20	20	20	20
260	20	20	20	20	20	20	20
265	20	20	20	20	20	20	20
270	20	20	20	20	20	20	20
275	20	20	20	20	20	20	20
280	20	20	20	20	20	20	20
285	20	20	20	20	20	20	20
290	20	20	20	20	20	20	20
295	25	20	20	20	20	20	20
300	25	25	20	20	20	20	20
330	30	25	25	20	20	20	20
400	35	30	25	25	20	20	20

60minutters brandmodstand: Stålprofiler under trapezlofter

Designtemp. Ap/V	350°C	400°C	450°C	500°C	550°C	600°C	650°C
40	20	20	20	20	20	20	20
45	20	20	20	20	20	20	20
50	20	20	20	20	20	20	20
55	20	20	20	20	20	20	20
60	20	20	20	20	20	20	20
65	25	20	20	20	20	20	20
70	25	20	20	20	20	20	20
75	25	20	20	20	20	20	20
80	25	25	20	20	20	20	20
85	25	25	20	20	20	20	20
90	25	25	20	20	20	20	20
95	30	25	25	20	20	20	20
100	30	25	25	20	20	20	20
105	30	25	25	20	20	20	20
110	30	30	25	20	20	20	20
115	30	30	25	20	20	20	20
120	30	30	25	25	20	20	20
125	35	30	25	25	20	20	20
130	35	30	30	25	20	20	20
135	35	30	30	25	20	20	20
140	35	30	30	25	25	20	20
145	35	35	30	25	25	20	20
150	40	35	30	30	25	20	20
155	40	35	30	30	25	20	20
160	40	35	30	30	25	20	20
165	40	35	35	30	25	25	20
170	40	35	35	30	30	25	20
175	40	40	35	30	30	25	20
180	45	40	35	30	30	25	20
185	45	40	35	35	30	25	20
190	45	40	35	35	30	25	25
195	45	40	35	35	30	30	25
200	45	40	40	35	30	30	25
205	45	40	40	35	30	30	25
210	50	45	40	35	35	30	25
215	50	45	40	35	35	30	25
220	50	45	40	35	35	30	30
225	50	45	40	35	35	30	30
230	50	45	40	40	35	30	30
235	55	45	40	40	35	35	30
240	55	50	45	40	35	35	30
245	55	50	45	40	35	35	30
250	55	50	45	40	35	35	30
255	55	50	45	40	40	35	30
260	55	50	45	40	40	35	30
265	60	50	45	40	40	35	35
270	60	50	45	45	40	35	35
275	60	55	50	45	40	35	35
280	60	55	50	45	40	35	35
285	60	55	50	45	40	35	35
290	-	55	50	45	40	40	35
295	-	55	50	45	40	40	35
300	-	55	50	45	40	40	35
330	-	60	55	50	45	40	40
400	-	-	-	60	55	50	45

90minutters brandmodstand: Stålprofiler under trapezlofter

Designtemp. Ap/V	350°C	400°C	450°C	500°C	550°C	600°C	650°C
40	25	25	20	20	20	20	20
45	25	25	20	20	20	20	20
50	30	25	25	20	20	20	20
55	30	25	25	20	20	20	20
60	30	30	25	20	20	20	20
65	30	30	25	25	20	20	20
70	30	30	30	25	20	20	20
75	35	30	30	25	25	20	20
80	35	30	30	25	25	20	20
85	35	35	30	30	25	25	20
90	40	35	30	30	25	25	20
95	40	35	35	30	30	25	20
100	40	40	35	30	30	25	25
105	45	40	35	35	30	30	25
110	45	40	35	35	30	30	25
115	45	40	40	35	30	30	25
120	50	45	40	35	35	30	30
125	50	45	40	35	35	30	30
130	50	45	40	40	35	30	30
135	55	45	45	40	35	35	30
140	55	50	45	40	35	35	30
145	55	50	45	40	40	35	30
150	60	50	45	40	40	35	35
155	60	55	45	45	40	35	35
160	60	55	50	45	40	35	35
165	-	55	50	45	40	40	35
170	-	55	50	45	40	40	35
175	-	60	50	45	45	40	35
180	-	60	55	50	45	40	40
185	-	60	55	50	45	40	40
190	-	60	55	50	45	45	40
195	-	-	55	50	45	45	40
200	-	-	60	55	50	45	40
205	-	-	60	55	50	45	40
210	-	-	60	55	50	45	40
215	-	-	60	55	50	45	45
220	-	-	-	55	50	50	45
225	-	-	-	60	55	50	45
230	-	-	-	60	55	50	45
235	-	-	-	60	55	50	45
240	-	-	-	60	55	50	45
245	-	-	-	60	55	50	50
250	-	-	-	-	60	55	50
255	-	-	-	-	60	55	50
260	-	-	-	-	60	55	50
265	-	-	-	-	60	55	50
270	-	-	-	-	60	55	50
275	-	-	-	-	60	55	50
280	-	-	-	-	-	60	55
285	-	-	-	-	-	60	55
290	-	-	-	-	-	60	55
295	-	-	-	-	-	60	55
300	-	-	-	-	-	60	55
330	-	-	-	-	-	-	60
400	-	-	-	-	-	-	-

120minutters brandmodstand: Stålprofiler under trapezlofter

Designtemp. Ap/V	350°C	400°C	450°C	500°C	550°C	600°C	650°C
40	30	25	25	20	20	20	20
45	30	30	25	25	20	20	20
50	35	30	30	25	20	20	20
55	35	35	30	25	25	20	20
60	40	35	30	30	25	25	20
65	40	35	35	30	30	25	20
70	45	40	35	30	30	25	25
75	45	40	35	35	30	30	25
80	50	45	40	35	35	30	30
85	50	45	40	35	35	30	30
90	55	45	40	40	35	35	30
95	55	50	45	40	35	35	30
100	60	50	45	40	40	35	35
105	60	55	50	45	40	35	35
110	60	55	50	45	40	40	35
115	-	55	50	45	45	40	35
120	-	60	55	50	45	40	40
125	-	60	55	50	45	40	40
130	-	-	55	50	45	45	40
135	-	-	60	55	50	45	40
140	-	-	60	55	50	45	40
145	-	-	60	55	50	45	45
150	-	-	-	60	55	50	45
155	-	-	-	60	55	50	45
160	-	-	-	60	55	50	45
165	-	-	-	-	55	50	50
170	-	-	-	-	60	55	50
175	-	-	-	-	60	55	50
180	-	-	-	-	60	55	50
185	-	-	-	-	-	55	55
190	-	-	-	-	-	60	55
195	-	-	-	-	-	60	55
200	-	-	-	-	-	60	55
205	-	-	-	-	-	-	55
210	-	-	-	-	-	-	60
215	-	-	-	-	-	-	60
220	-	-	-	-	-	-	60
225	-	-	-	-	-	-	60
230	-	-	-	-	-	-	-
235	-	-	-	-	-	-	-
240	-	-	-	-	-	-	-
245	-	-	-	-	-	-	-
250	-	-	-	-	-	-	-
255	-	-	-	-	-	-	-
260	-	-	-	-	-	-	-
265	-	-	-	-	-	-	-
270	-	-	-	-	-	-	-
275	-	-	-	-	-	-	-
280	-	-	-	-	-	-	-
285	-	-	-	-	-	-	-
290	-	-	-	-	-	-	-
295	-	-	-	-	-	-	-
300	-	-	-	-	-	-	-
330	-	-	-	-	-	-	-
400	-	-	-	-	-	-	-

180minutters brandmodstand: Stålprofiler under trapezlofter

Designtemp. Ap/V	350°C	400°C	450°C	500°C	550°C	600°C	650°C
40	40	40	35	30	30	25	25
45	45	40	40	35	30	30	25
50	50	45	40	40	35	30	30
55	55	50	45	40	35	35	30
60	60	55	45	45	40	35	35
65	-	55	50	45	40	40	35
70	-	60	55	50	45	40	40
75	-	-	55	50	45	45	40
80	-	-	60	55	50	45	40
85	-	-	-	55	50	50	45
90	-	-	-	60	55	50	45
95	-	-	-	-	55	55	50
100	-	-	-	-	60	55	50
105	-	-	-	-	60	55	55
110	-	-	-	-	-	60	55
115	-	-	-	-	-	60	55
120	-	-	-	-	-	-	60
125	-	-	-	-	-	-	60
130	-	-	-	-	-	-	-
135	-	-	-	-	-	-	-
140	-	-	-	-	-	-	-
145	-	-	-	-	-	-	-
150	-	-	-	-	-	-	-
155	-	-	-	-	-	-	-
160	-	-	-	-	-	-	-
165	-	-	-	-	-	-	-
170	-	-	-	-	-	-	-
175	-	-	-	-	-	-	-
180	-	-	-	-	-	-	-
185	-	-	-	-	-	-	-
190	-	-	-	-	-	-	-
195	-	-	-	-	-	-	-
200	-	-	-	-	-	-	-
205	-	-	-	-	-	-	-
210	-	-	-	-	-	-	-
215	-	-	-	-	-	-	-
220	-	-	-	-	-	-	-
225	-	-	-	-	-	-	-
230	-	-	-	-	-	-	-
235	-	-	-	-	-	-	-
240	-	-	-	-	-	-	-
245	-	-	-	-	-	-	-
250	-	-	-	-	-	-	-
255	-	-	-	-	-	-	-
260	-	-	-	-	-	-	-
265	-	-	-	-	-	-	-
270	-	-	-	-	-	-	-
275	-	-	-	-	-	-	-
280	-	-	-	-	-	-	-
285	-	-	-	-	-	-	-
290	-	-	-	-	-	-	-
295	-	-	-	-	-	-	-
300	-	-	-	-	-	-	-
330	-	-	-	-	-	-	-
400	-	-	-	-	-	-	-

Vores produktionsanlæg

Takket være vores moderniserede og automatiserede produktionsanlæg i Skamol Branden og Skamol Opole, Business Unit Boards, har vores tekniske isoleringssystem SkamoStructure opnået et unikt kvalitetsniveau med hensyn til stabilitet og egenskaber. Dette har ikke alene ført til høj og ensartet kvalitet, men også til en effektiv behandling af standardiserede løsninger og hurtige leveringstider.

En af de væsentligste fordele ved vores SkamoStructure Board er, at de er yderst lette og ikke går i stykker under ekstreme temperaturer eller temperatursvingninger.

Plader til alsidige applikationer

Hovedproduktet i vores Business Unit Boards er plader, der kan bruges til forskellige isoleringsopgaver. Dette omfatter fx industriel højtemperaturisolering, passiv brandsikring, skimmelforebyggelse og pejsbeklædning.

Vores kunder kan også bestille individuelle størrelser i større mængder, ligesom vi kan gennemføre mindre produktionstests og inspektioner for at sikre en effektiv produktionsproces, inden vi påbegynder storproduktion.

Noter



A series of horizontal lines forming a ruled area for taking notes, set against a light gray background.

All in  **one**



Se mere på www.skamol.com