

Passive fire protection for building structures



We make the difference



Skamol Group develops, produces and distributes insulation construction material for a wide range of heat-intensive industry sectors, as well as for passive fire protection, fireplace enclosures and for mould prevention.

With our products and solutions, we would like to help our partners and customers gain considerable added value and at the same time make our contribution to the environment. With the use of our unique materials we are able to benefit from many advantages, including energy savings, greater performance, better working and living conditions and even lower CO2 emissions.

Skamol was founded in Denmark in 1912, with the purpose of utilizing the local deposits of the unique diatomaceous earth, also known as moler.

Since then, the company has grown into a leading, global supplier of technical insulation systems for both industrial and private use. Besides the use of moler (diatomite), we have expanded our product range to include vermiculite and calcium silicate.

At the front edge of developing technical insulation systems

As a modern company, we are among the world leaders in research and system development, as well as new techniques and technologies. Our production plants in Denmark, Poland and Russia are kept state-of-the-art to ensure continuously high system quality; an attribute that often proves vital for our customers.

We believe in the value of close cooperation and dialogue. Just like we develop new products with new properties, we improve and modify existing systems. In doing so, we pay particular attention to our customers' requests and consider the market requirement in general.

Table of contents

Fire protection for steel structures	4	30minutes fire resistance: Closed profiles	17
Application areas	5	60minutes fire resistance: Closed profiles	18
Construction steel.	6	90minutes fire resistance: Closed profiles	19
Thickness of the SkamoStructure Board 250	6	120minutes fire resistance: Closed profiles	20
SkamoStructure Board 250 sizes	7	180minutes fire resistance: Closed profiles	21
Mounting.	7	30minutes fire resistance: Open profiles	22
3-sided square cladding	8	60minutes fire resistance: Open profiles	23
4-sided square cladding	9	90minutes fire resistance: Open profiles	24
3-sided square cladding	10	120minutes fire resistance: Open profiles	25
4-sided square cladding	11	180minutes fire resistance: Open profiles	26
4-sided square cladding	12	SkamoStructure Board 250 protected steel beams mounted under trapeze ceilings	27
Datasheet: SkamoStructure Board 250	13	30minutes fire resistance: Steel beams mounted under trapeze ceilings	28
Find the applicable board thickness	14	60minutes fire resistance: Steel beams mounted under trapeze ceilings	29
Examples for the calculation of cladding	15	90minutes fire resistance: Steel beams mounted under trapeze ceilings	30
Am/V ratio.	16	120minutes fire resistance: Steel beams mounted under trapeze ceilings	31
		180minutes fire resistance: Steel beams mounted under trapeze ceilings	32
		Our production facilities	33



Fire protection for steel structures

The serious alternative to conventional solutions for the passive fire protection of steel constructions

Skamol now offers the market a serious alternative to conventional solutions for the passive fire protection of steel constructions.

For years the unique solutions on the market were “cement-bound fire protection boards” or fire-resistant plasterboards for these applications, and SkamoStructure offers a real alternative.

The SkamoStructure Board 250 consists of calcium silicate and offers considerable advantages compared to conventional solutions.

Our advantage: The simplest handling

One factor makes SkamoStructure stand out in particular: Our boards are extremely light. This means the material can be handled very easily. Attaching it is no problem either – see page 7 for all of the attachment methods that can be used to mount SkamoStructure exactly where it's needed.



DANMARK
11/0469

The protection of load-bearing structural elements against fire is a decisive factor in order to meet state building codes with respect to fire protection and thus to ensure the structural stability of a building in the event of a fire. Our SkamoStructure lightweight construction system is the perfect solution for protecting steel building structures. No matter whether it's for open profiles, closed profiles or columns: SkamoStructure is ETA certified and reliably protects the building structure.

Cement-bound fire protection boards.

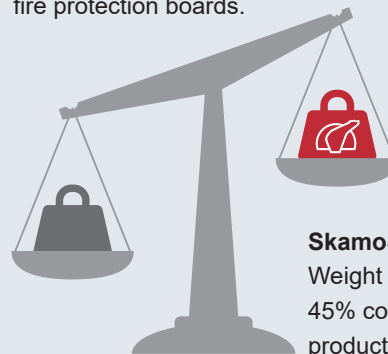

SkamoStructure Board 250
Weight reduction of around 45% compared to other products on the market.



Lightweight

SkamoStructure Board 250 weighs just 250kg/m³.



Quick mounting

SkamoStructure is quick and easy to mount.



Fire protection

SkamoStructure is a Class A1 construction material.

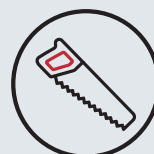

Easy to handle

SkamoStructure can be handled without the need for any special tools.

Application areas



Beam with open profile.



Beam with closed profile.

Versatile and absolutely safe – important arguments that speak for SkamoStructure

SkamoStructure can be used to protect all relevant parts of the building structure: Columns, beams and supports can all be clad regards whether as open or closed profiles.

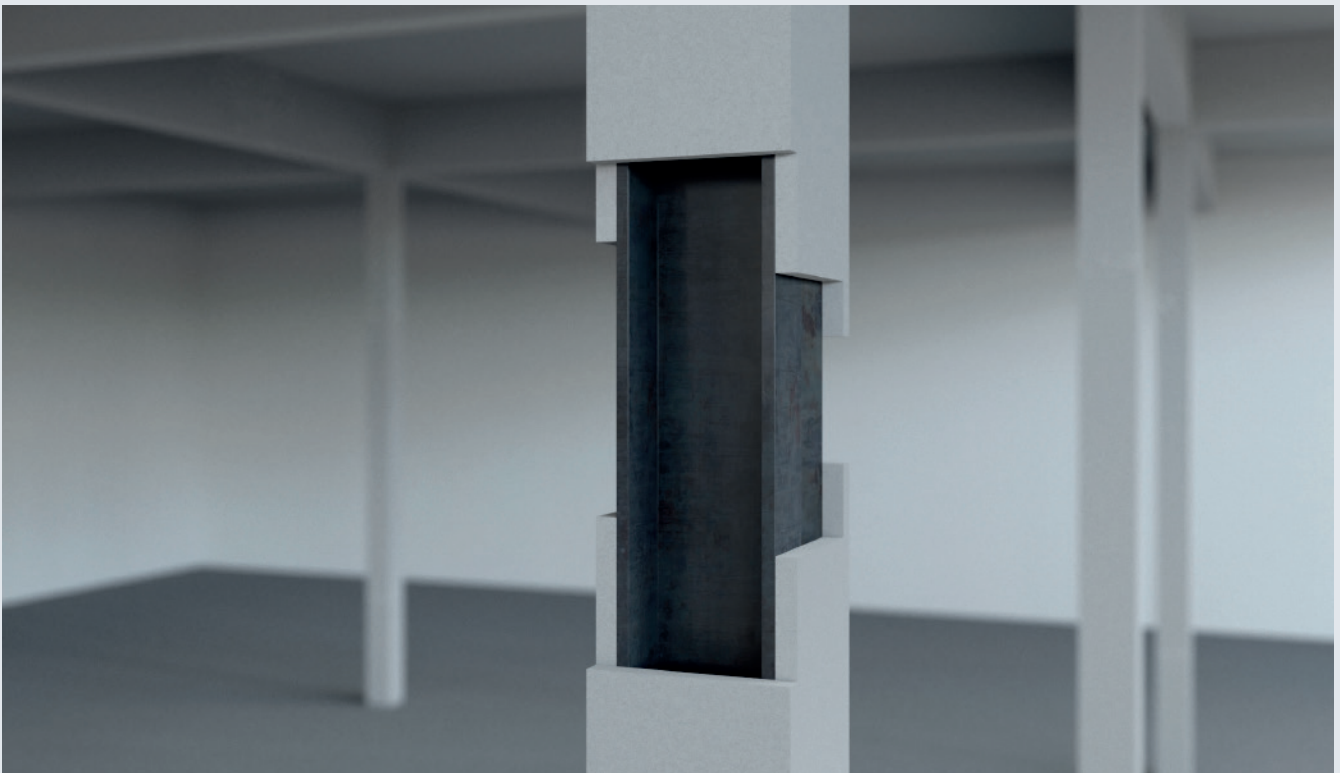

Column with open profile.

Construction steel

Construction regulations stipulate how long some construction elements must be able to withstand fire in the event that a fire breaks out. The necessary structural fire protection depends on the following factors:

- Predetermined fire resistance time
- Shape and size of the steel element
- Proportion of the steel profile exposed to fire
- Type of fire protection used

The SkamoStructure system has been tested in approved labs according to the testing procedure for determining the contribution to fire resistance of load-bearing structural components (EN 13381-4).

The system is approved for load-bearing steel beams and columns in accordance with ETA-11/00469. The SkamoStructure Board is used as square cladding for open and hollow profiles to protect the steel.

Thickness of the SkamoStructure Board 250

The section factor, the critical steel temperature and the fire resistance requirement must be taken into account when selecting the board thickness.

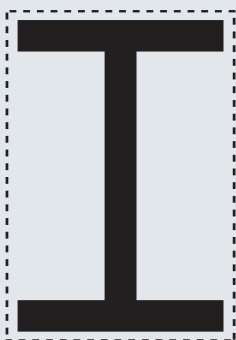

Box protection.

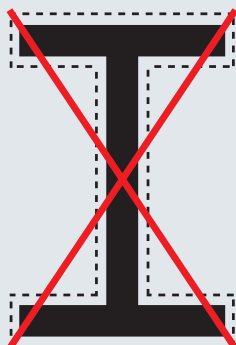

Profile protection.

Section factor

The section factor is a parameter used to determine the thermal behaviour of steel structural components. The fundamental factors are the rate at which the steel supports and columns heat up proportional to the area exposed to fire (A_p) and in reverse proportion to the volume of the steel profile (V). The section factor is calculated using the formula A_p/V and measured in m^{-1} , and the value depends on whether the area of the steel beam exposed to fire is 3-sided or 4-sided and the structural component thickness. The section factor for steel profiles can be provided by the supplier of the steel.

Critical steel temperature

The critical steel temperature specifies at what temperature structural weaknesses could occur because of the fire. The critical steel temperature can be provided by the supplier of the steel.

Fire resistance requirement

Construction regulations stipulate how long some construction elements must be able to withstand the fire in the event that a fire breaks out.

SkamoStructure Board 250 sizes

Product number	Size	Packaging	m ² / packaging	Piece per pallet
24160001	2,440 × 1,220 × 22mm	Piece	2.98m ²	47
24160002	2,440 × 1,220 × 25mm	Piece	2.98m ²	42
24160003	2,440 × 1,220 × 30mm	Piece	2.98m ²	35
24160004	2,440 × 1,220 × 35mm	Piece	2.98m ²	30
24160005	2,440 × 1,220 × 40mm	Piece	2.98m ²	26
24160007	2,440 × 1,220 × 45mm	Piece	2.98m ²	23
24160008	2,440 × 1,220 × 50mm	Piece	2.98m ²	21
24160009	2,440 × 1,220 × 55mm	Piece	2.98m ²	19
24160010	2,440 × 1,220 × 60mm	Piece	2.98m ²	17

Mounting

The SkamoStructure Board is attached using screws or shot nails with a 30mm washer, as listed in table.

SkamoStructure Board 250	Screws for open and closed profiles		Shot nails with 30mm washers for closed profiles	
	Thickness	Maximum screw spacing	Screw dimensions	Maximum shot nail spacing
22	340mm	3.8 × 45mm	-	-
25	340mm	3.8 × 45mm	460mm	37mm
30	340mm	4.0 × 60mm	460mm	42mm
35	340mm	4.0 × 70mm	460mm	47mm
40	340mm	5.0 × 80mm	460mm	52mm
45	340mm	5.0 × 90mm	460mm	57mm
50	340mm	5.0 × 90mm	460mm	62mm
55	340mm	5.0 × 100mm	-	-
60	340mm	5.0 × 110mm	-	-

Skamol recommends the use of galvanised wood/multi-material screws and shot nails with the dimensions, as specified above in the table.

For mounting under trapeze ceilings Skamol recommends the use of drywall/particle board screws in accordance with the dimension in the mounting table above.

3-sided square cladding



All dimensions are in mm.

Position of screws in open profiled steel – three-sided protection

For a more rigid structure the board joints should be offset by ≥ 300 mm

The structural supports should be sawn off with a minimum width of 200mm and 1-2mm excess in the height, so that they can be pressed in between the flanges. The structural supports should be cut with the same sheet thickness as the formwork. The columns should be affixed to every joint and at a maximum distance of 1200mm from one another.

See screw information on page 7.

4-sided square cladding

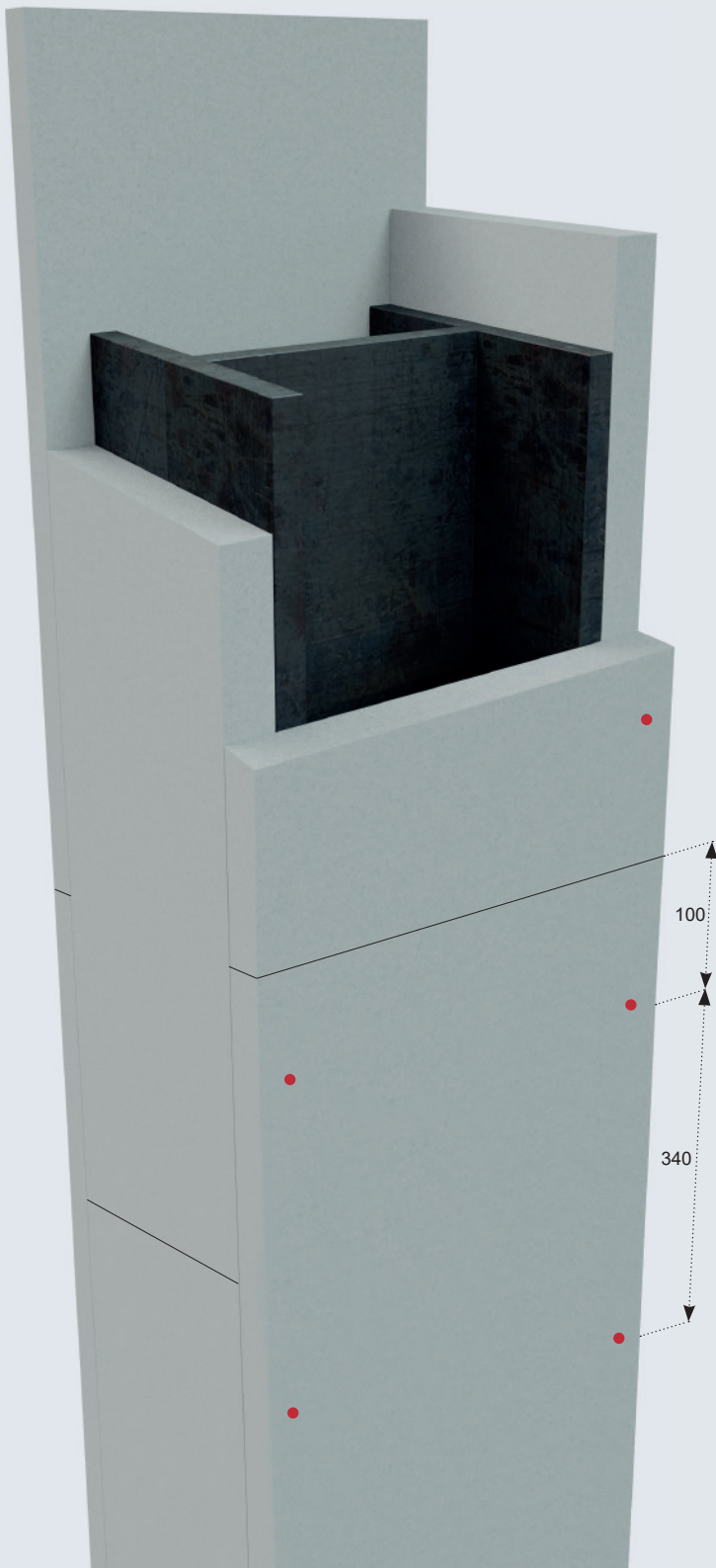

All dimensions are inmm.

Position of screws in open profiled steel – four-sided protection

For a more rigid structure the board joints should be offset by $\geq 300\text{mm}$

See screw information on page 7.

3-sided square cladding

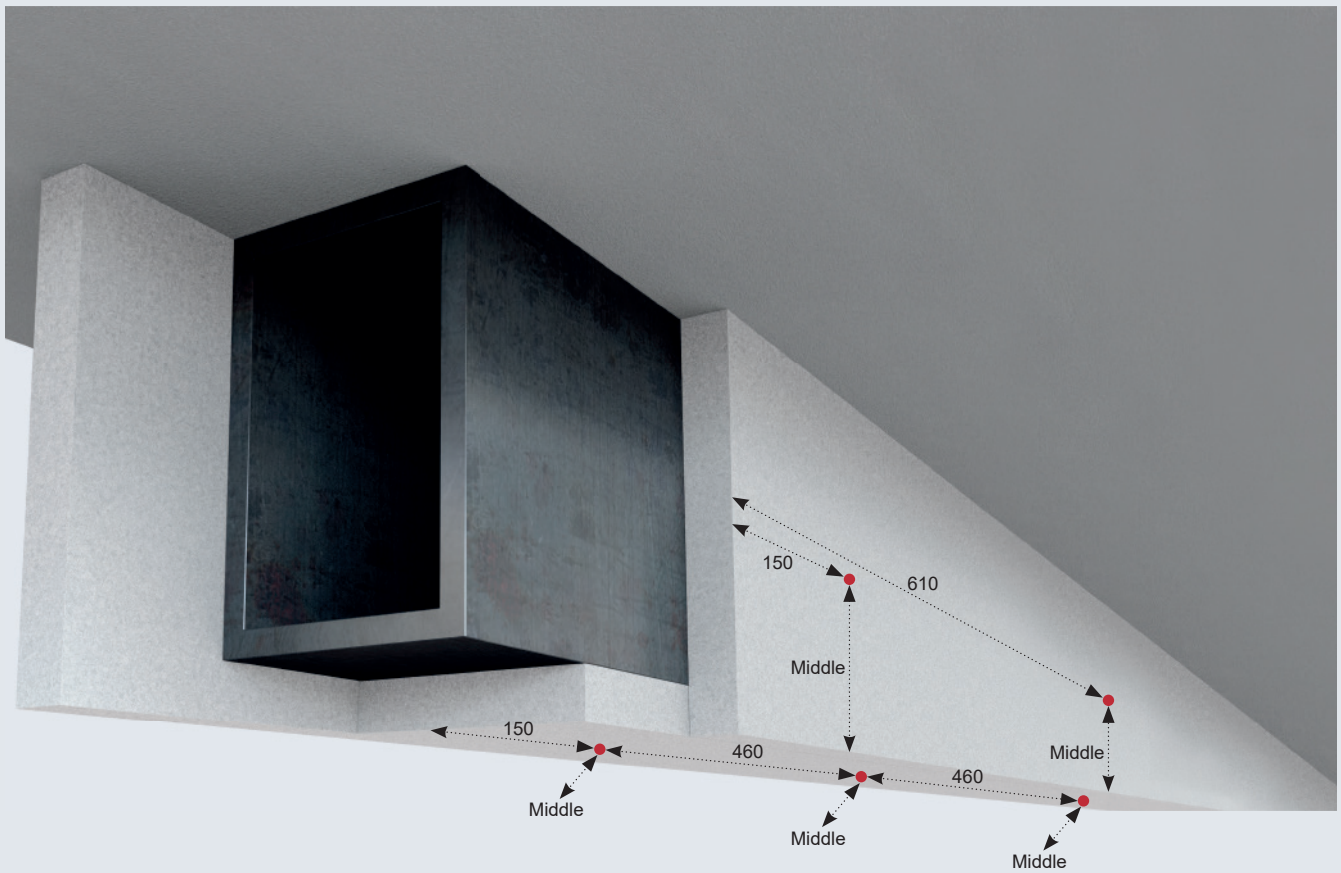

All dimensions are in mm.

Position of shot nails in closed profiled steel – three-sided protection

For a more rigid structure the board joints should be offset by ≥ 300 mm.

See screw information on page 7.

4-sided square cladding

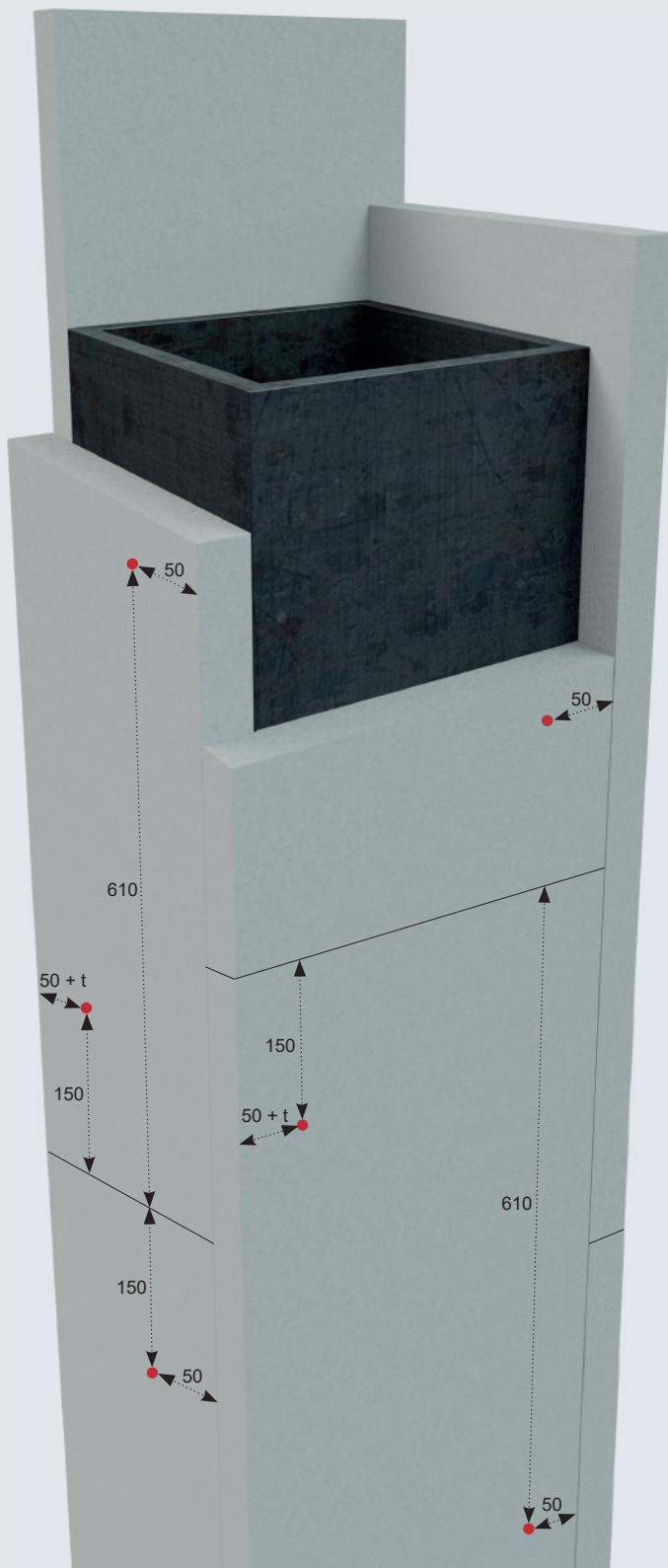

All dimensions are inmm.

t = SkamoStructure Board 250 thickness.

Position of shot nails in closed profiled steel – four-sided protection

For a more rigid structure the board joints should be offset by ≥ 300 mm.

See screw information on page 7.

4-sided square cladding

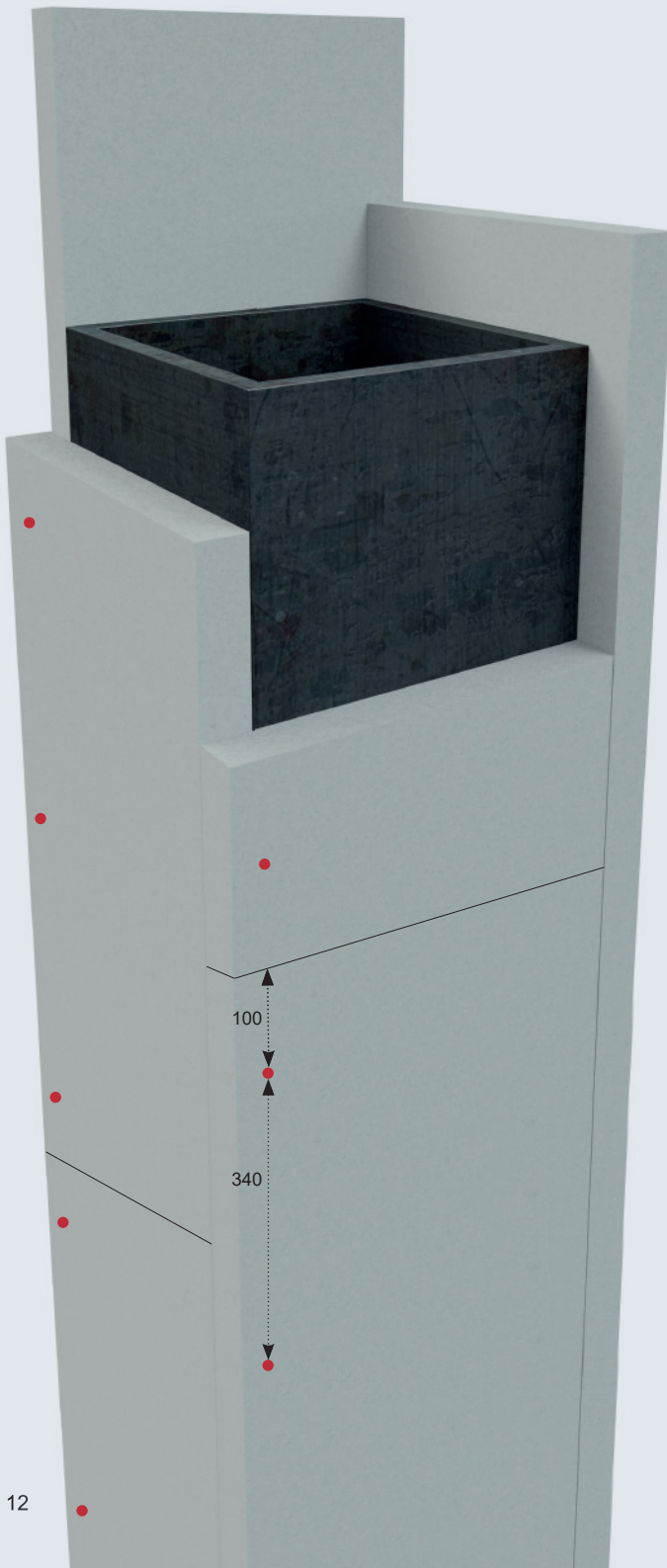

All dimensions inmm.

Position of screws in closed profiled steel – four-sided protection

For a more rigid structure the board joints should be offset by $\geq 300\text{mm}$.

See screw information on page 7.

Datasheet: SkamoStructure Board 250

	Value	Unit
Non-combustibility tests (EN 13501-1:2007 + A1:2009)	Class A1	
Loadbearing steel beam and column protection (EN 13381-4)	Up to 180	minutes
Weather exposure category	Y (semi-exposure)	
Bulk density	250	kg/m ³
	16	lb/ft ³
Board weight (25mm thickness)	6.3	kg/m ²
	1.2	lb/ft ²
Cold crushing strength (DS/EN ISO 8895_2006)	2.8	MPa
	406	lb/in ²
Modulus of rupture (EN 993-6:1995)	1.3	MPa
	189	lb/in ²
Total porosity (EN 1094-4:1995)	90	%
Water content	2.5	%
Dimension stability under specified temp. and humidity conditions (EN 1604) at 23°C, 90% RH, 4 hours	0.0	%
Thermal conductivity (EN 12667), λ_{10}	0.073	W/(m×K)
	0.514	BTU/(ft ² ×h×°F/in)
Sound reduction index ($R_w(C;C_{tr})$)	Thickness	
	60mm	28 (-1;-3) dB
HS Tariff number (Harmonized Commodity Description and Coding System)	6806.90.00	
Colour	Grey	



Find the applicable board thickness

For the dimensioning of fire protection of steel structures, it is important to identify the critical steel temperature for the steel profile. The critical steel temperature appears on the project material or can be specified by the project consultant.

Apart from the critical steel temperature the A_p/V ratio (section factor) of the steel profile which needs to be protected, must also be taken into consideration. The tables on page 16 show the section factor of the most common steel profile.

When you know the A_p/V ratio for the steel profile, you can determine which SkamoStructure Board 250 thickness is to be used at a critical temperature of 500°C in the table to right.

Formula for calculating the A_p/V ratio for box protection

A_p = inner circumference of the shielding.
 A_p is the sum of the inner circumference of the smallest possible rectangle or square.

V = cross-sectional area of the profile.

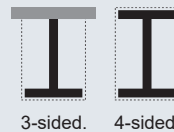

After calculation of the A_p/V value the section factor of the box protection must always be rounded up.

Critical temperature of 500°C (open profile)

Time (min)	A_p/V	Thickness (mm)
30	40-400	22
60	40-185	22
60	186-210	25
60	211-250	30
60	251-295	35
60	296-330	40
60	331-400	50
90	40-105	22
90	106-115	25
90	116-140	30
90	140-165	35
90	166-185	40
90	186-210	45
90	211-235	50
90	236-260	55
90	261-280	60
120	40-70	22
120	71-80	25
120	81-95	30
120	96-110	35
120	111-125	40
120	126-140	45
120	141-155	50
120	156-170	55
120	171-185	60
180	40	22
180	41-45	25
180	46-50	30
180	51-60	35
180	61-70	40
180	71-80	45
180	81-90	50
180	91-95	55
180	96-105	60

Examples for the calculation of cladding

Examples for the calculation of three-sided cladding

A steel profile, IPE 200, must be fire-protected from three sides, and the fire resistance must be R60.

$$A_p = 2 \times 0.20\text{m} + 0.10\text{m} = 0.50\text{m}$$

$$V = 2,850\text{mm}^2 \approx 0.00285\text{m}^2$$

$$A_p/V = 0.50\text{m} / 0.00285\text{m}^2 \approx 176\text{m}^{-1}$$

Thickness of SkamoStructure Board 250 according to table on page 14 = 22mm

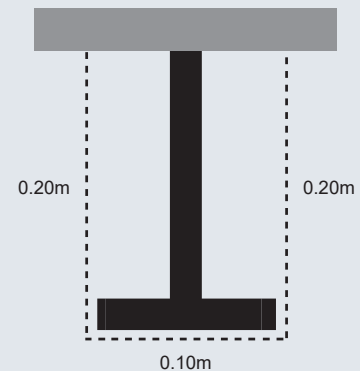

Examples for the calculation of four-sided cladding

A steel profile, HE 120 A, must be fire-protected from three sides, and the fire resistance must be R90.

$$A_p = 2 \times 0.114\text{m} + 2 \times 0.120\text{m} = 0.468\text{m}$$

$$V = 2,534\text{mm}^2 \approx 0.002534\text{m}^2$$

$$A_p/V = 0.468\text{m} / 0.002534\text{m}^2 \approx 184\text{m}^{-1}$$

Thickness of SkamoStructure Board 250 according to table on page 14 = 40mm

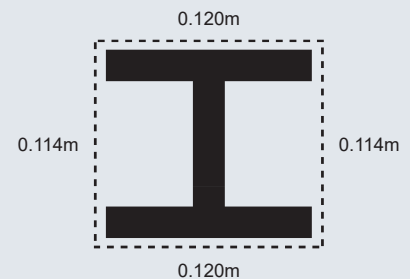

Ap/V ratio

Ap/V ratio for the most commonly used steel profile is shown in the table below.

Square (mm)	3-sided	4-sided
100 × 100 × 4	198	264
100 × 100 × 5	161	214
100 × 100 × 6	136	181
100 × 100 × 8	105	139
100 × 100 × 10	86	115
120 × 120 × 5	159	212
120 × 120 × 6	134	178
120 × 120 × 8	103	137
120 × 120 × 10	84	112
140 × 140 × 5	158	210
140 × 140 × 6	133	177
140 × 140 × 8	101	135
140 × 140 × 10	83	111
150 × 150 × 5	157	210
150 × 150 × 6	132	176
150 × 150 × 8	101	134
150 × 150 × 10	82	110

Square (mm)	3-sided	4-sided
150 × 150 × 12.5	68	90
150 × 150 × 16	55	73
160 × 160 × 5	157	209
160 × 160 × 6	132	175
160 × 160 × 8	83	111
160 × 160 × 10	82	109
180 × 180 × 5	156	208
180 × 180 × 6.3	125	167
180 × 180 × 8	100	133
180 × 180 × 10	81	108
200 × 200 × 5	156	207
200 × 200 × 6.3	124	166
200 × 200 × 8	99	132
200 × 200 × 10	81	107
200 × 200 × 12.5	66	87
200 × 200 × 16	53	70

HEA	3-sided	4-sided	HEB	3-sided	4-sided	IPE	3-sided	4-sided	HEM	3-sided	4-sided
HE 100A	138	185	HE 100B	115	154	IPE 80	270	330	HE 100M	65	85
HE 120A	137	185	HE 120B	106	141	IPE 100	247	300	HE 120M	61	80
HE 140A	129	174	HE 140B	98	130	IPE 120	230	279	HE 140M	58	76
HE 160A	120	161	HE 160B	89	118	IPE 140	215	259	HE 160M	54	71
HE 180A	115	155	HE 180B	83	110	IPE 160	200	241	HE 180M	52	68
HE 200A	108	145	HE 200B	77	103	IPE 180	188	226	HE 200M	49	65
HE 220A	100	134	HE 220B	73	97	IPE 200	176	211	HE 220M	47	62
HE 240A	91	122	HE 240B	68	91	IPE 220	165	198	HE 240M	40	52
HE 260A	88	118	HE 260B	66	88	IPE 240	153	184	HE 260M	39	51
HE 280A	84	113	HE 280B	64	85	IPE 270	147	176	HE 280M	38	50
HE 300A	78	105	HE 300B	60	81	IPE 300	139	167	HE 300M	33	43
HE 320A	74	98	HE 320B	58	77	IPE 330	131	156	HE 320M	33	43
HE 340A	72	94	HE 340B	57	75	IPE 360	122	146	HE 340M	33	43
HE 360A	70	91	HE 360B	57	73	IPE 400	116	137			
HE 400A	68	87	HE 400B	56	71	IPE 450	110	130			
HE 450A	66	83	HE 450B	55	69	IPE 500	104	121			
HE 500A	65	80	HE 500B	55	67	IPE 550	98	113			
HE 550A	65	79	HE 550B	55	67	IPE 600	91	105			
HE 600A	65	79	HE 600B	55	67						
			HE 650B	55	66						

Source: Teknisk Ståbi

30minutes fire resistance: Closed profiles

Design temp. Ap/V	350°C	400°C	450°C	500°C	550°C	600°C	650°C	700°C
60	25.0	25.0	25.0	25.0	25.0	25.0	25.0	25.0
65	25.0	25.0	25.0	25.0	25.0	25.0	25.0	25.0
70	25.0	25.0	25.0	25.0	25.0	25.0	25.0	25.0
75	25.0	25.0	25.0	25.0	25.0	25.0	25.0	25.0
80	25.0	25.0	25.0	25.0	25.0	25.0	25.0	25.0
85	25.0	25.0	25.0	25.0	25.0	25.0	25.0	25.0
90	25.0	25.0	25.0	25.0	25.0	25.0	25.0	25.0
95	25.0	25.0	25.0	25.0	25.0	25.0	25.0	25.0
100	25.0	25.0	25.0	25.0	25.0	25.0	25.0	25.0
105	25.0	25.0	25.0	25.0	25.0	25.0	25.0	25.0
110	25.0	25.0	25.0	25.0	25.0	25.0	25.0	25.0
115	25.0	25.0	25.0	25.0	25.0	25.0	25.0	25.0
120	25.0	25.0	25.0	25.0	25.0	25.0	25.0	25.0
125	25.0	25.0	25.0	25.0	25.0	25.0	25.0	25.0
130	25.0	25.0	25.0	25.0	25.0	25.0	25.0	25.0
135	25.0	25.0	25.0	25.0	25.0	25.0	25.0	25.0
140	25.0	25.0	25.0	25.0	25.0	25.0	25.0	25.0
145	25.0	25.0	25.0	25.0	25.0	25.0	25.0	25.0
150	25.0	25.0	25.0	25.0	25.0	25.0	25.0	25.0
155	25.0	25.0	25.0	25.0	25.0	25.0	25.0	25.0
160	25.0	25.0	25.0	25.0	25.0	25.0	25.0	25.0
165	25.0	25.0	25.0	25.0	25.0	25.0	25.0	25.0
170	25.0	25.0	25.0	25.0	25.0	25.0	25.0	25.0
175	25.0	25.0	25.0	25.0	25.0	25.0	25.0	25.0
180	25.0	25.0	25.0	25.0	25.0	25.0	25.0	25.0
185	25.0	25.0	25.0	25.0	25.0	25.0	25.0	25.0
190	25.0	25.0	25.0	25.0	25.0	25.0	25.0	25.0
195	25.0	25.0	25.0	25.0	25.0	25.0	25.0	25.0
200	25.0	25.0	25.0	25.0	25.0	25.0	25.0	25.0
205	25.0	25.0	25.0	25.0	25.0	25.0	25.0	25.0
210	25.0	25.0	25.0	25.0	25.0	25.0	25.0	25.0
215	25.0	25.0	25.0	25.0	25.0	25.0	25.0	25.0
220	25.0	25.0	25.0	25.0	25.0	25.0	25.0	25.0
225	25.0	25.0	25.0	25.0	25.0	25.0	25.0	25.0
230	25.0	25.0	25.0	25.0	25.0	25.0	25.0	25.0
235	25.0	25.0	25.0	25.0	25.0	25.0	25.0	25.0
240	30.0	25.0	25.0	25.0	25.0	25.0	25.0	25.0
245	30.0	25.0	25.0	25.0	25.0	25.0	25.0	25.0
250	30.0	25.0	25.0	25.0	25.0	25.0	25.0	25.0
255	30.0	25.0	25.0	25.0	25.0	25.0	25.0	25.0
260	30.0	25.0	25.0	25.0	25.0	25.0	25.0	25.0
265	30.0	25.0	25.0	25.0	25.0	25.0	25.0	25.0
270	30.0	25.0	25.0	25.0	25.0	25.0	25.0	25.0
275	30.0	25.0	25.0	25.0	25.0	25.0	25.0	25.0
280	30.0	25.0	25.0	25.0	25.0	25.0	25.0	25.0
285	30.0	25.0	25.0	25.0	25.0	25.0	25.0	25.0
290	30.0	25.0	25.0	25.0	25.0	25.0	25.0	25.0

60minutes fire resistance: Closed profiles

Design temp. Ap/V	350°C	400°C	450°C	500°C	550°C	600°C	650°C	700°C
60	25.0	25.0	25.0	25.0	25.0	25.0	25.0	25.0
65	25.0	25.0	25.0	25.0	25.0	25.0	25.0	25.0
70	30.0	25.0	25.0	25.0	25.0	25.0	25.0	25.0
75	30.0	25.0	25.0	25.0	25.0	25.0	25.0	25.0
80	30.0	25.0	25.0	25.0	25.0	25.0	25.0	25.0
85	30.0	25.0	25.0	25.0	25.0	25.0	25.0	25.0
90	30.0	25.0	25.0	25.0	25.0	25.0	25.0	25.0
95	30.0	25.0	25.0	25.0	25.0	25.0	25.0	25.0
100	30.0	30.0	25.0	25.0	25.0	25.0	25.0	25.0
105	30.0	30.0	25.0	25.0	25.0	25.0	25.0	25.0
110	30.0	30.0	25.0	25.0	25.0	25.0	25.0	25.0
115	35.0	30.0	25.0	25.0	25.0	25.0	25.0	25.0
120	35.0	30.0	25.0	25.0	25.0	25.0	25.0	25.0
125	35.0	30.0	25.0	25.0	25.0	25.0	25.0	25.0
130	35.0	30.0	25.0	25.0	25.0	25.0	25.0	25.0
135	35.0	30.0	30.0	25.0	25.0	25.0	25.0	25.0
140	35.0	30.0	30.0	25.0	25.0	25.0	25.0	25.0
145	35.0	30.0	30.0	25.0	25.0	25.0	25.0	25.0
150	35.0	35.0	30.0	25.0	25.0	25.0	25.0	25.0
155	35.0	35.0	30.0	25.0	25.0	25.0	25.0	25.0
160	40.0	35.0	30.0	25.0	25.0	25.0	25.0	25.0
165	40.0	35.0	30.0	25.0	25.0	25.0	25.0	25.0
170	40.0	35.0	30.0	25.0	25.0	25.0	25.0	25.0
175	40.0	35.0	30.0	25.0	25.0	25.0	25.0	25.0
180	40.0	35.0	30.0	25.0	25.0	25.0	25.0	25.0
185	40.0	35.0	30.0	25.0	25.0	25.0	25.0	25.0
190	40.0	35.0	30.0	30.0	25.0	25.0	25.0	25.0
195	40.0	35.0	30.0	30.0	25.0	25.0	25.0	25.0
200	40.0	35.0	30.0	30.0	25.0	25.0	25.0	25.0
205	45.0	35.0	35.0	30.0	25.0	25.0	25.0	25.0
210	45.0	40.0	35.0	30.0	25.0	25.0	25.0	25.0
215	45.0	40.0	35.0	30.0	25.0	25.0	25.0	25.0
220	45.0	40.0	35.0	30.0	25.0	25.0	25.0	25.0
225	45.0	40.0	35.0	30.0	25.0	25.0	25.0	25.0
230	45.0	40.0	35.0	30.0	25.0	25.0	25.0	25.0
235	45.0	40.0	35.0	30.0	25.0	25.0	25.0	25.0
240	45.0	40.0	35.0	30.0	25.0	25.0	25.0	25.0
245	45.0	40.0	35.0	30.0	25.0	25.0	25.0	25.0
250	45.0	40.0	35.0	30.0	25.0	25.0	25.0	25.0
255	45.0	40.0	35.0	30.0	25.0	25.0	25.0	25.0
260	50.0	40.0	35.0	30.0	25.0	25.0	25.0	25.0
265	50.0	40.0	35.0	30.0	25.0	25.0	25.0	25.0
270	50.0	40.0	35.0	30.0	25.0	25.0	25.0	25.0
275	50.0	40.0	35.0	30.0	30.0	25.0	25.0	25.0
280	50.0	40.0	35.0	30.0	30.0	25.0	25.0	25.0
285	50.0	45.0	35.0	30.0	30.0	25.0	25.0	25.0
290	50.0	45.0	35.0	30.0	30.0	25.0	25.0	25.0

90minutes fire resistance: Closed profiles

Design temp. Ap/V	350°C	400°C	450°C	500°C	550°C	600°C	650°C	700°C
60	30.0	30.0	25.0	25.0	25.0	25.0	25.0	25.0
65	35.0	30.0	25.0	25.0	25.0	25.0	25.0	25.0
70	35.0	30.0	30.0	25.0	25.0	25.0	25.0	25.0
75	35.0	30.0	30.0	25.0	25.0	25.0	25.0	25.0
80	35.0	35.0	30.0	25.0	25.0	25.0	25.0	25.0
85	35.0	35.0	30.0	30.0	25.0	25.0	25.0	25.0
90	40.0	35.0	30.0	30.0	25.0	25.0	25.0	25.0
95	40.0	35.0	30.0	30.0	25.0	25.0	25.0	25.0
100	40.0	35.0	35.0	30.0	25.0	25.0	25.0	25.0
105	40.0	35.0	35.0	30.0	25.0	25.0	25.0	25.0
110	40.0	40.0	35.0	30.0	30.0	25.0	25.0	25.0
115	45.0	40.0	35.0	30.0	30.0	25.0	25.0	25.0
120	45.0	40.0	35.0	30.0	30.0	25.0	25.0	25.0
125	45.0	40.0	35.0	35.0	30.0	25.0	25.0	25.0
130	45.0	40.0	35.0	35.0	30.0	25.0	25.0	25.0
135	45.0	40.0	40.0	35.0	30.0	30.0	25.0	25.0
140	45.0	45.0	40.0	35.0	30.0	30.0	25.0	25.0
145	50.0	45.0	40.0	35.0	30.0	30.0	25.0	25.0
150	50.0	45.0	40.0	35.0	30.0	30.0	25.0	25.0
155	50.0	45.0	40.0	35.0	35.0	30.0	25.0	25.0
160	50.0	45.0	40.0	35.0	35.0	30.0	25.0	25.0
165	50.0	45.0	40.0	40.0	35.0	30.0	25.0	25.0
170	55.0	45.0	40.0	40.0	35.0	30.0	30.0	25.0
175	55.0	50.0	45.0	40.0	35.0	30.0	30.0	25.0
180	55.0	50.0	45.0	40.0	35.0	30.0	30.0	25.0
185		50.0	45.0	40.0	35.0	30.0	30.0	25.0
190		50.0	45.0	40.0	35.0	30.0	30.0	25.0
195		50.0	45.0	40.0	35.0	35.0	30.0	25.0
200		50.0	45.0	40.0	35.0	35.0	30.0	25.0
205		50.0	45.0	40.0	35.0	35.0	30.0	25.0
210		55.0	45.0	40.0	40.0	35.0	30.0	25.0
215		55.0	45.0	40.0	40.0	35.0	30.0	25.0
220		55.0	50.0	45.0	40.0	35.0	30.0	30.0
225		55.0	50.0	45.0	40.0	35.0	30.0	30.0
230			50.0	45.0	40.0	35.0	30.0	30.0
235			50.0	45.0	40.0	35.0	30.0	30.0
240			50.0	45.0	40.0	35.0	30.0	30.0
245			50.0	45.0	40.0	35.0	30.0	30.0
250			50.0	45.0	40.0	35.0	30.0	30.0
255			50.0	45.0	40.0	35.0	30.0	30.0
260			50.0	45.0	40.0	35.0	35.0	30.0
265			50.0	45.0	40.0	35.0	35.0	30.0
270			55.0	45.0	40.0	35.0	35.0	30.0
275			55.0	45.0	40.0	35.0	35.0	30.0
280			55.0	45.0	40.0	40.0	35.0	30.0
285			55.0	50.0	40.0	40.0	35.0	30.0
290			55.0	50.0	45.0	40.0	35.0	30.0

120minutes fire resistance: Closed profiles

Design temp. Ap/V	350°C	400°C	450°C	500°C	550°C	600°C	650°C	700°C
60	35.0	35.0	30.0	30.0	25.0	25.0	25.0	25.0
65	40.0	35.0	35.0	30.0	25.0	25.0	25.0	25.0
70	40.0	35.0	35.0	30.0	30.0	25.0	25.0	25.0
75	40.0	40.0	35.0	30.0	30.0	25.0	25.0	25.0
80	45.0	40.0	35.0	35.0	30.0	30.0	25.0	25.0
85	45.0	40.0	40.0	35.0	30.0	30.0	25.0	25.0
90	45.0	40.0	40.0	35.0	35.0	30.0	25.0	25.0
95	45.0	45.0	40.0	35.0	35.0	30.0	30.0	25.0
100	50.0	45.0	40.0	40.0	35.0	30.0	30.0	25.0
105	50.0	45.0	40.0	40.0	35.0	30.0	30.0	25.0
110	50.0	45.0	45.0	40.0	35.0	35.0	30.0	25.0
115	50.0	50.0	45.0	40.0	35.0	35.0	30.0	30.0
120	55.0	50.0	45.0	40.0	40.0	35.0	30.0	30.0
125		50.0	45.0	40.0	40.0	35.0	30.0	30.0
130		50.0	45.0	45.0	40.0	35.0	35.0	30.0
135		55.0	50.0	45.0	40.0	35.0	35.0	30.0
140		55.0	50.0	45.0	40.0	35.0	35.0	30.0
145		55.0	50.0	45.0	40.0	40.0	35.0	30.0
150			50.0	45.0	45.0	40.0	35.0	30.0
155			50.0	45.0	45.0	40.0	35.0	35.0
160			55.0	50.0	45.0	40.0	35.0	35.0
165			55.0	50.0	45.0	40.0	35.0	35.0
170			55.0	50.0	45.0	40.0	40.0	35.0
175				50.0	45.0	40.0	40.0	35.0
180				50.0	45.0	40.0	40.0	35.0
185				50.0	45.0	45.0	40.0	35.0
190				50.0	50.0	45.0	40.0	35.0
195				55.0	50.0	45.0	40.0	35.0
200				55.0	50.0	45.0	40.0	35.0
205				55.0	50.0	45.0	40.0	35.0
210					50.0	45.0	40.0	35.0
215					50.0	45.0	40.0	40.0
220					50.0	45.0	40.0	40.0
225					50.0	45.0	40.0	40.0
230					50.0	45.0	45.0	40.0
235					50.0	45.0	45.0	40.0
240					55.0	50.0	45.0	40.0
245					55.0	50.0	45.0	40.0
250					55.0	50.0	45.0	40.0
255					55.0	50.0	45.0	40.0
260					55.0	50.0	45.0	40.0
265						50.0	45.0	40.0
270						50.0	45.0	40.0
275						50.0	45.0	40.0
280						50.0	45.0	40.0
285						50.0	45.0	40.0
290						50.0	45.0	40.0

180minutes fire resistance: Closed profiles

Design temp. Ap/V	350°C	400°C	450°C	500°C	550°C	600°C	650°C	700°C
60	50.0	45.0	40.0	40.0	35.0	35.0	30.0	30.0
65	50.0	45.0	45.0	40.0	40.0	35.0	35.0	30.0
70	50.0	50.0	45.0	45.0	40.0	35.0	35.0	30.0
75	55.0	50.0	50.0	45.0	40.0	40.0	35.0	35.0
80		55.0	50.0	45.0	45.0	40.0	40.0	35.0
85			50.0	50.0	45.0	40.0	40.0	35.0
90			55.0	50.0	45.0	45.0	40.0	40.0
95				50.0	50.0	45.0	40.0	40.0
100				55.0	50.0	45.0	45.0	40.0
105					50.0	50.0	45.0	40.0
110					55.0	50.0	45.0	40.0
115					55.0	50.0	45.0	45.0
120						50.0	50.0	45.0
125						55.0	50.0	45.0
130						55.0	50.0	45.0
135							50.0	45.0
140							50.0	50.0
145							55.0	50.0
150							55.0	50.0
155							55.0	50.0
160								50.0
165								50.0
170								55.0
175								55.0
180								55.0
185								
190								
195								
200								
205								
210								
215								
220								
225								
230								
235								
240								
245								
250								
255								
260								
265								
270								
275								
280								
285								
290								

30minutes fire resistance: Open profiles

Design temp. Ap/V	350°C	400°C	450°C	500°C	550°C	600°C	650°C
40	22.0	22.0	22.0	22.0	22.0	22.0	22.0
45	22.0	22.0	22.0	22.0	22.0	22.0	22.0
50	22.0	22.0	22.0	22.0	22.0	22.0	22.0
55	22.0	22.0	22.0	22.0	22.0	22.0	22.0
60	22.0	22.0	22.0	22.0	22.0	22.0	22.0
65	22.0	22.0	22.0	22.0	22.0	22.0	22.0
70	22.0	22.0	22.0	22.0	22.0	22.0	22.0
75	22.0	22.0	22.0	22.0	22.0	22.0	22.0
80	22.0	22.0	22.0	22.0	22.0	22.0	22.0
85	22.0	22.0	22.0	22.0	22.0	22.0	22.0
90	22.0	22.0	22.0	22.0	22.0	22.0	22.0
95	22.0	22.0	22.0	22.0	22.0	22.0	22.0
100	22.0	22.0	22.0	22.0	22.0	22.0	22.0
105	22.0	22.0	22.0	22.0	22.0	22.0	22.0
110	22.0	22.0	22.0	22.0	22.0	22.0	22.0
115	22.0	22.0	22.0	22.0	22.0	22.0	22.0
120	22.0	22.0	22.0	22.0	22.0	22.0	22.0
125	22.0	22.0	22.0	22.0	22.0	22.0	22.0
130	22.0	22.0	22.0	22.0	22.0	22.0	22.0
135	22.0	22.0	22.0	22.0	22.0	22.0	22.0
140	22.0	22.0	22.0	22.0	22.0	22.0	22.0
145	22.0	22.0	22.0	22.0	22.0	22.0	22.0
150	22.0	22.0	22.0	22.0	22.0	22.0	22.0
155	22.0	22.0	22.0	22.0	22.0	22.0	22.0
160	22.0	22.0	22.0	22.0	22.0	22.0	22.0
165	22.0	22.0	22.0	22.0	22.0	22.0	22.0
170	22.0	22.0	22.0	22.0	22.0	22.0	22.0
175	22.0	22.0	22.0	22.0	22.0	22.0	22.0
180	22.0	22.0	22.0	22.0	22.0	22.0	22.0
185	22.0	22.0	22.0	22.0	22.0	22.0	22.0
190	22.0	22.0	22.0	22.0	22.0	22.0	22.0
195	22.0	22.0	22.0	22.0	22.0	22.0	22.0
200	22.0	22.0	22.0	22.0	22.0	22.0	22.0
205	22.0	22.0	22.0	22.0	22.0	22.0	22.0
210	22.0	22.0	22.0	22.0	22.0	22.0	22.0
215	22.0	22.0	22.0	22.0	22.0	22.0	22.0
220	22.0	22.0	22.0	22.0	22.0	22.0	22.0
225	22.0	22.0	22.0	22.0	22.0	22.0	22.0
230	22.0	22.0	22.0	22.0	22.0	22.0	22.0
235	22.0	22.0	22.0	22.0	22.0	22.0	22.0
240	22.0	22.0	22.0	22.0	22.0	22.0	22.0
245	22.0	22.0	22.0	22.0	22.0	22.0	22.0
250	22.0	22.0	22.0	22.0	22.0	22.0	22.0
255	22.0	22.0	22.0	22.0	22.0	22.0	22.0
260	22.0	22.0	22.0	22.0	22.0	22.0	22.0
265	22.0	22.0	22.0	22.0	22.0	22.0	22.0
270	22.0	22.0	22.0	22.0	22.0	22.0	22.0
275	22.0	22.0	22.0	22.0	22.0	22.0	22.0
280	22.0	22.0	22.0	22.0	22.0	22.0	22.0
285	22.0	22.0	22.0	22.0	22.0	22.0	22.0
290	22.0	22.0	22.0	22.0	22.0	22.0	22.0
295	22.0	22.0	22.0	22.0	22.0	22.0	22.0
300	22.0	22.0	22.0	22.0	22.0	22.0	22.0
330	22.0	22.0	22.0	22.0	22.0	22.0	22.0
400	30.0	25.0	22.0	22.0	22.0	22.0	22.0

60minutes fire resistance: Open profiles

Design temp. Ap/V	350°C	400°C	450°C	500°C	550°C	600°C	650°C
40	22.0	22.0	22.0	22.0	22.0	22.0	22.0
45	22.0	22.0	22.0	22.0	22.0	22.0	22.0
50	22.0	22.0	22.0	22.0	22.0	22.0	22.0
55	22.0	22.0	22.0	22.0	22.0	22.0	22.0
60	22.0	22.0	22.0	22.0	22.0	22.0	22.0
65	22.0	22.0	22.0	22.0	22.0	22.0	22.0
70	22.0	22.0	22.0	22.0	22.0	22.0	22.0
75	22.0	22.0	22.0	22.0	22.0	22.0	22.0
80	22.0	22.0	22.0	22.0	22.0	22.0	22.0
85	22.0	22.0	22.0	22.0	22.0	22.0	22.0
90	22.0	22.0	22.0	22.0	22.0	22.0	22.0
95	22.0	22.0	22.0	22.0	22.0	22.0	22.0
100	22.0	22.0	22.0	22.0	22.0	22.0	22.0
105	22.0	22.0	22.0	22.0	22.0	22.0	22.0
110	22.0	22.0	22.0	22.0	22.0	22.0	22.0
115	22.0	22.0	22.0	22.0	22.0	22.0	22.0
120	22.0	22.0	22.0	22.0	22.0	22.0	22.0
125	25.0	22.0	22.0	22.0	22.0	22.0	22.0
130	25.0	22.0	22.0	22.0	22.0	22.0	22.0
135	25.0	22.0	22.0	22.0	22.0	22.0	22.0
140	25.0	22.0	22.0	22.0	22.0	22.0	22.0
145	30.0	25.0	22.0	22.0	22.0	22.0	22.0
150	30.0	25.0	22.0	22.0	22.0	22.0	22.0
155	30.0	25.0	22.0	22.0	22.0	22.0	22.0
160	30.0	25.0	22.0	22.0	22.0	22.0	22.0
165	30.0	30.0	25.0	22.0	22.0	22.0	22.0
170	35.0	30.0	25.0	22.0	22.0	22.0	22.0
175	35.0	30.0	25.0	22.0	22.0	22.0	22.0
180	35.0	30.0	25.0	22.0	22.0	22.0	22.0
185	35.0	30.0	25.0	22.0	22.0	22.0	22.0
190	35.0	30.0	30.0	25.0	22.0	22.0	22.0
195	35.0	30.0	30.0	25.0	22.0	22.0	22.0
200	40.0	35.0	30.0	25.0	22.0	22.0	22.0
205	40.0	35.0	30.0	25.0	22.0	22.0	22.0
210	40.0	35.0	30.0	25.0	22.0	22.0	22.0
215	40.0	35.0	30.0	30.0	25.0	22.0	22.0
220	40.0	35.0	30.0	30.0	25.0	22.0	22.0
225	45.0	35.0	35.0	30.0	25.0	22.0	22.0
230	45.0	40.0	35.0	30.0	25.0	22.0	22.0
235	45.0	40.0	35.0	30.0	25.0	22.0	22.0
240	45.0	40.0	35.0	30.0	30.0	25.0	22.0
245	45.0	40.0	35.0	30.0	30.0	25.0	22.0
250	45.0	40.0	35.0	30.0	30.0	25.0	22.0
255	50.0	40.0	35.0	35.0	30.0	25.0	22.0
260	50.0	40.0	35.0	35.0	30.0	25.0	22.0
265	50.0	45.0	40.0	35.0	30.0	25.0	25.0
270	50.0	45.0	40.0	35.0	30.0	30.0	25.0
275	50.0	45.0	40.0	35.0	30.0	30.0	25.0
280	55.0	45.0	40.0	35.0	30.0	30.0	25.0
285	55.0	45.0	40.0	35.0	30.0	30.0	25.0
290	55.0	45.0	40.0	35.0	35.0	30.0	25.0
295	55.0	50.0	40.0	35.0	35.0	30.0	25.0
300	55.0	50.0	45.0	40.0	35.0	30.0	25.0
330	60.0	55.0	45.0	40.0	35.0	35.0	30.0
400			55.0	50.0	45.0	40.0	35.0

90minutes fire resistance: Open profiles

Design temp. Ap/V	350°C	400°C	450°C	500°C	550°C	600°C	650°C
40	22.0	22.0	22.0	22.0	22.0	22.0	22.0
45	22.0	22.0	22.0	22.0	22.0	22.0	22.0
50	22.0	22.0	22.0	22.0	22.0	22.0	22.0
55	22.0	22.0	22.0	22.0	22.0	22.0	22.0
60	22.0	22.0	22.0	22.0	22.0	22.0	22.0
65	22.0	22.0	22.0	22.0	22.0	22.0	22.0
70	22.0	22.0	22.0	22.0	22.0	22.0	22.0
75	25.0	22.0	22.0	22.0	22.0	22.0	22.0
80	25.0	22.0	22.0	22.0	22.0	22.0	22.0
85	30.0	25.0	22.0	22.0	22.0	22.0	22.0
90	30.0	25.0	22.0	22.0	22.0	22.0	22.0
95	30.0	30.0	25.0	22.0	22.0	22.0	22.0
100	35.0	30.0	25.0	22.0	22.0	22.0	22.0
105	35.0	30.0	25.0	22.0	22.0	22.0	22.0
110	35.0	30.0	30.0	25.0	22.0	22.0	22.0
115	40.0	35.0	30.0	25.0	22.0	22.0	22.0
120	40.0	35.0	30.0	30.0	25.0	22.0	22.0
125	40.0	35.0	30.0	30.0	25.0	22.0	22.0
130	45.0	40.0	35.0	30.0	25.0	22.0	22.0
135	45.0	40.0	35.0	30.0	30.0	25.0	22.0
140	45.0	40.0	35.0	30.0	30.0	25.0	22.0
145	50.0	40.0	35.0	35.0	30.0	25.0	22.0
150	50.0	45.0	40.0	35.0	30.0	30.0	25.0
155	50.0	45.0	40.0	35.0	30.0	30.0	25.0
160	55.0	45.0	40.0	35.0	30.0	30.0	25.0
165	55.0	45.0	40.0	35.0	35.0	30.0	25.0
170	55.0	50.0	45.0	40.0	35.0	30.0	30.0
175	60.0	50.0	45.0	40.0	35.0	30.0	30.0
180	60.0	50.0	45.0	40.0	35.0	35.0	30.0
185	60.0	55.0	45.0	40.0	35.0	35.0	30.0
190		55.0	50.0	45.0	40.0	35.0	30.0
195		55.0	50.0	45.0	40.0	35.0	30.0
200		55.0	50.0	45.0	40.0	35.0	35.0
205		60.0	50.0	45.0	40.0	35.0	35.0
210		60.0	55.0	45.0	40.0	40.0	35.0
215		60.0	55.0	50.0	45.0	40.0	35.0
220			55.0	50.0	45.0	40.0	35.0
225			55.0	50.0	45.0	40.0	35.0
230			55.0	50.0	45.0	40.0	35.0
235			60.0	50.0	45.0	40.0	40.0
240			60.0	55.0	50.0	45.0	40.0
245			60.0	55.0	50.0	45.0	40.0
250			60.0	55.0	50.0	45.0	40.0
255				55.0	50.0	45.0	40.0
260				55.0	50.0	45.0	40.0
265				60.0	50.0	45.0	45.0
270				60.0	55.0	50.0	45.0
275				60.0	55.0	50.0	45.0
280				60.0	55.0	50.0	45.0
285					55.0	50.0	45.0
290					55.0	50.0	45.0
295					60.0	50.0	45.0
300					60.0	55.0	50.0
330						60.0	50.0
400							

120minutes fire resistance: Open profiles

Design temp. Ap/V	350°C	400°C	450°C	500°C	550°C	600°C	650°C
40	22.0	22.0	22.0	22.0	22.0	22.0	22.0
45	22.0	22.0	22.0	22.0	22.0	22.0	22.0
50	25.0	22.0	22.0	22.0	22.0	22.0	22.0
55	30.0	22.0	22.0	22.0	22.0	22.0	22.0
60	30.0	25.0	22.0	22.0	22.0	22.0	22.0
65	35.0	30.0	25.0	22.0	22.0	22.0	22.0
70	35.0	30.0	25.0	22.0	22.0	22.0	22.0
75	40.0	35.0	30.0	25.0	22.0	22.0	22.0
80	40.0	35.0	30.0	25.0	25.0	22.0	22.0
85	40.0	35.0	35.0	30.0	25.0	22.0	22.0
90	45.0	40.0	35.0	30.0	30.0	25.0	22.0
95	45.0	40.0	35.0	30.0	30.0	25.0	22.0
100	50.0	45.0	40.0	35.0	30.0	30.0	25.0
105	50.0	45.0	40.0	35.0	30.0	30.0	25.0
110	55.0	45.0	40.0	35.0	35.0	30.0	25.0
115	55.0	50.0	45.0	40.0	35.0	30.0	30.0
120	60.0	50.0	45.0	40.0	35.0	35.0	30.0
125	60.0	55.0	45.0	40.0	40.0	35.0	30.0
130		55.0	50.0	45.0	40.0	35.0	30.0
135		55.0	50.0	45.0	40.0	35.0	35.0
140		60.0	50.0	45.0	40.0	40.0	35.0
145		60.0	55.0	50.0	45.0	40.0	35.0
150			55.0	50.0	45.0	40.0	35.0
155			60.0	50.0	45.0	40.0	40.0
160			60.0	55.0	50.0	45.0	40.0
165			60.0	55.0	50.0	45.0	40.0
170				55.0	50.0	45.0	40.0
175				60.0	50.0	45.0	40.0
180				60.0	55.0	50.0	45.0
185				60.0	55.0	50.0	45.0
190					55.0	50.0	45.0
195					60.0	50.0	45.0
200					60.0	55.0	50.0
205					60.0	55.0	50.0
210					60.0	55.0	50.0
215						55.0	50.0
220						60.0	55.0
225						60.0	55.0
230						60.0	55.0
235						60.0	55.0
240							55.0
245							60.0
250							60.0
255							60.0
260							60.0
265							
270							
275							
280							
285							
290							
295							
300							
330							
400							

180minutes fire resistance: Open profiles

Design temp. Ap/V	350°C	400°C	450°C	500°C	550°C	600°C	650°C
40	35.0	30.0	25.0	22.0	22.0	22.0	22.0
45	40.0	35.0	30.0	25.0	22.0	22.0	22.0
50	45.0	35.0	35.0	30.0	25.0	22.0	22.0
55	45.0	40.0	35.0	35.0	30.0	25.0	22.0
60	50.0	45.0	40.0	35.0	30.0	30.0	25.0
65	55.0	50.0	45.0	40.0	35.0	30.0	30.0
70	60.0	50.0	45.0	40.0	35.0	35.0	30.0
75		55.0	50.0	45.0	40.0	35.0	30.0
80		60.0	50.0	45.0	40.0	40.0	35.0
85			55.0	50.0	45.0	40.0	35.0
90			60.0	50.0	45.0	40.0	40.0
95			60.0	55.0	50.0	45.0	40.0
100				60.0	50.0	45.0	45.0
105				60.0	55.0	50.0	45.0
110					55.0	50.0	45.0
115					60.0	55.0	50.0
120					60.0	55.0	50.0
125						60.0	55.0
130						60.0	55.0
135							55.0
140							60.0
145							60.0
150							
155							
160							
165							
170							
175							
180							
185							
190							
195							
200							
205							
210							
215							
220							
225							
230							
235							
240							
245							
250							
255							
260							
265							
270							
275							
280							
285							
290							
295							
300							
330							
400							

SkamoStructure Board 250 protected steel beams mounted under trapeze ceilings

Assessed DK R30 to R180

- The section factor for the beam must be calculated as a 4-sided fire exposure.
- The surface area of contact between the top flange of the beam and the trapeze ceiling must be 40% or lower than the total top surface area of the beam.
- The thickness of the SkamoStructure Board 250 are given in the attached design tables and must be the same for the sides and the top blocking piece placed between the trapeze profile.
- The trapeze ceiling must be filled with a non-combustible material e.g. mineral wool and must not contain air gaps.
- The thickness of the steel sheeting of the trapeze ceiling must be 1.2mm or lower.
- All gaps between the SkamoStructure Board 250 and the trapeze ceiling must be filled with fire sealant.
- Drawings of the construction with the assessed changes is attached to this assessment.
- The assessment is only valid for the requirements in test standard ENV 13381-4: 2002.
- All other details must be constructed as described in assessment report PH13583_rev1.

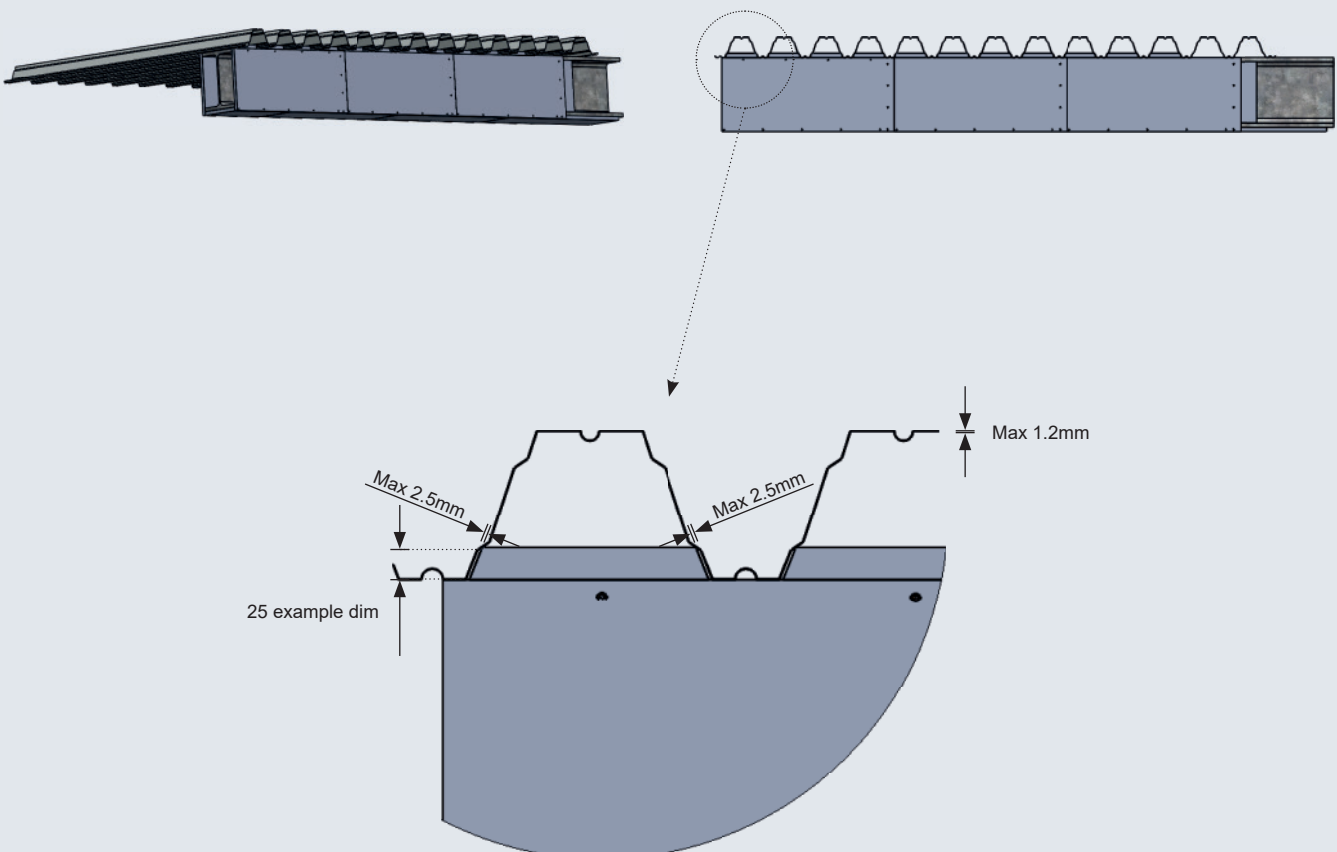

30minutes fire resistance: Steel beams mounted under trapeze ceilings

Design temp. Ap/V	350°C	400°C	450°C	500°C	550°C	600°C	650°C
40	20	20	20	20	20	20	20
45	20	20	20	20	20	20	20
50	20	20	20	20	20	20	20
55	20	20	20	20	20	20	20
60	20	20	20	20	20	20	20
65	20	20	20	20	20	20	20
70	20	20	20	20	20	20	20
75	20	20	20	20	20	20	20
80	20	20	20	20	20	20	20
85	20	20	20	20	20	20	20
90	20	20	20	20	20	20	20
95	20	20	20	20	20	20	20
100	20	20	20	20	20	20	20
105	20	20	20	20	20	20	20
110	20	20	20	20	20	20	20
115	20	20	20	20	20	20	20
120	20	20	20	20	20	20	20
125	20	20	20	20	20	20	20
130	20	20	20	20	20	20	20
135	20	20	20	20	20	20	20
140	20	20	20	20	20	20	20
145	20	20	20	20	20	20	20
150	20	20	20	20	20	20	20
155	20	20	20	20	20	20	20
160	20	20	20	20	20	20	20
165	20	20	20	20	20	20	20
170	20	20	20	20	20	20	20
175	20	20	20	20	20	20	20
180	20	20	20	20	20	20	20
185	20	20	20	20	20	20	20
190	20	20	20	20	20	20	20
195	20	20	20	20	20	20	20
200	20	20	20	20	20	20	20
205	20	20	20	20	20	20	20
210	20	20	20	20	20	20	20
215	20	20	20	20	20	20	20
220	20	20	20	20	20	20	20
225	20	20	20	20	20	20	20
230	20	20	20	20	20	20	20
235	20	20	20	20	20	20	20
240	20	20	20	20	20	20	20
245	20	20	20	20	20	20	20
250	20	20	20	20	20	20	20
255	20	20	20	20	20	20	20
260	20	20	20	20	20	20	20
265	20	20	20	20	20	20	20
270	20	20	20	20	20	20	20
275	20	20	20	20	20	20	20
280	20	20	20	20	20	20	20
285	20	20	20	20	20	20	20
290	20	20	20	20	20	20	20
295	25	20	20	20	20	20	20
300	25	25	20	20	20	20	20
330	30	25	25	20	20	20	20
400	35	30	25	25	20	20	20

60minutes fire resistance: Steel beams mounted under trapeze ceilings

Design temp. Ap/V	350°C	400°C	450°C	500°C	550°C	600°C	650°C
40	20	20	20	20	20	20	20
45	20	20	20	20	20	20	20
50	20	20	20	20	20	20	20
55	20	20	20	20	20	20	20
60	20	20	20	20	20	20	20
65	25	20	20	20	20	20	20
70	25	20	20	20	20	20	20
75	25	20	20	20	20	20	20
80	25	25	20	20	20	20	20
85	25	25	20	20	20	20	20
90	25	25	20	20	20	20	20
95	30	25	25	20	20	20	20
100	30	25	25	20	20	20	20
105	30	25	25	20	20	20	20
110	30	30	25	20	20	20	20
115	30	30	25	20	20	20	20
120	30	30	25	25	20	20	20
125	35	30	25	25	20	20	20
130	35	30	30	25	20	20	20
135	35	30	30	25	20	20	20
140	35	30	30	25	25	20	20
145	35	35	30	25	25	20	20
150	40	35	30	30	25	20	20
155	40	35	30	30	25	20	20
160	40	35	30	30	25	20	20
165	40	35	35	30	25	25	20
170	40	35	35	30	30	25	20
175	40	40	35	30	30	25	20
180	45	40	35	30	30	25	20
185	45	40	35	35	30	25	20
190	45	40	35	35	30	25	25
195	45	40	35	35	30	30	25
200	45	40	40	35	30	30	25
205	45	40	40	35	30	30	25
210	50	45	40	35	35	30	25
215	50	45	40	35	35	30	25
220	50	45	40	35	35	30	30
225	50	45	40	35	35	30	30
230	50	45	40	40	35	30	30
235	55	45	40	40	35	35	30
240	55	50	45	40	35	35	30
245	55	50	45	40	35	35	30
250	55	50	45	40	35	35	30
255	55	50	45	40	40	35	30
260	55	50	45	40	40	35	30
265	60	50	45	40	40	35	35
270	60	50	45	45	40	35	35
275	60	55	50	45	40	35	35
280	60	55	50	45	40	35	35
285	60	55	50	45	40	35	35
290	-	55	50	45	40	40	35
295	-	55	50	45	40	40	35
300	-	55	50	45	40	40	35
330	-	60	55	50	45	40	40
400	-	-	-	60	55	50	45

90minutes fire resistance: Steel beams mounted under trapeze ceilings

Design temp. Ap/V	350°C	400°C	450°C	500°C	550°C	600°C	650°C
40	25	25	20	20	20	20	20
45	25	25	20	20	20	20	20
50	30	25	25	20	20	20	20
55	30	25	25	20	20	20	20
60	30	30	25	20	20	20	20
65	30	30	25	25	20	20	20
70	30	30	30	25	20	20	20
75	35	30	30	25	25	20	20
80	35	30	30	25	25	20	20
85	35	35	30	30	25	25	20
90	40	35	30	30	25	25	20
95	40	35	35	30	30	25	20
100	40	40	35	30	30	25	25
105	45	40	35	35	30	30	25
110	45	40	35	35	30	30	25
115	45	40	40	35	30	30	25
120	50	45	40	35	35	30	30
125	50	45	40	35	35	30	30
130	50	45	40	40	35	30	30
135	55	45	45	40	35	35	30
140	55	50	45	40	35	35	30
145	55	50	45	40	40	35	30
150	60	50	45	40	40	35	35
155	60	55	45	45	40	35	35
160	60	55	50	45	40	35	35
165	-	55	50	45	40	40	35
170	-	55	50	45	40	40	35
175	-	60	50	45	45	40	35
180	-	60	55	50	45	40	40
185	-	60	55	50	45	40	40
190	-	60	55	50	45	45	40
195	-	-	55	50	45	45	40
200	-	-	60	55	50	45	40
205	-	-	60	55	50	45	40
210	-	-	60	55	50	45	40
215	-	-	60	55	50	45	45
220	-	-	-	55	50	50	45
225	-	-	-	60	55	50	45
230	-	-	-	60	55	50	45
235	-	-	-	60	55	50	45
240	-	-	-	60	55	50	45
245	-	-	-	60	55	50	50
250	-	-	-	-	60	55	50
255	-	-	-	-	60	55	50
260	-	-	-	-	60	55	50
265	-	-	-	-	60	55	50
270	-	-	-	-	60	55	50
275	-	-	-	-	60	55	50
280	-	-	-	-	-	60	55
285	-	-	-	-	-	60	55
290	-	-	-	-	-	60	55
295	-	-	-	-	-	60	55
300	-	-	-	-	-	60	55
330	-	-	-	-	-	-	60
400	-	-	-	-	-	-	-

120minutes fire resistance: Steel beams mounted under trapeze ceilings

Design temp. Ap/V	350°C	400°C	450°C	500°C	550°C	600°C	650°C
40	30	25	25	20	20	20	20
45	30	30	25	25	20	20	20
50	35	30	30	25	20	20	20
55	35	35	30	25	25	20	20
60	40	35	30	30	25	25	20
65	40	35	35	30	30	25	20
70	45	40	35	30	30	25	25
75	45	40	35	35	30	30	25
80	50	45	40	35	35	30	30
85	50	45	40	35	35	30	30
90	55	45	40	40	35	35	30
95	55	50	45	40	35	35	30
100	60	50	45	40	40	35	35
105	60	55	50	45	40	35	35
110	60	55	50	45	40	40	35
115	-	55	50	45	45	40	35
120	-	60	55	50	45	40	40
125	-	60	55	50	45	40	40
130	-	-	55	50	45	45	40
135	-	-	60	55	50	45	40
140	-	-	60	55	50	45	40
145	-	-	60	55	50	45	45
150	-	-	-	60	55	50	45
155	-	-	-	60	55	50	45
160	-	-	-	60	55	50	45
165	-	-	-	-	55	50	50
170	-	-	-	-	60	55	50
175	-	-	-	-	60	55	50
180	-	-	-	-	60	55	50
185	-	-	-	-	-	55	55
190	-	-	-	-	-	60	55
195	-	-	-	-	-	60	55
200	-	-	-	-	-	60	55
205	-	-	-	-	-	-	55
210	-	-	-	-	-	-	60
215	-	-	-	-	-	-	60
220	-	-	-	-	-	-	60
225	-	-	-	-	-	-	60
230	-	-	-	-	-	-	-
235	-	-	-	-	-	-	-
240	-	-	-	-	-	-	-
245	-	-	-	-	-	-	-
250	-	-	-	-	-	-	-
255	-	-	-	-	-	-	-
260	-	-	-	-	-	-	-
265	-	-	-	-	-	-	-
270	-	-	-	-	-	-	-
275	-	-	-	-	-	-	-
280	-	-	-	-	-	-	-
285	-	-	-	-	-	-	-
290	-	-	-	-	-	-	-
295	-	-	-	-	-	-	-
300	-	-	-	-	-	-	-
330	-	-	-	-	-	-	-
400	-	-	-	-	-	-	-

180minutes fire resistance: Steel beams mounted under trapeze ceilings

Design temp. Ap/V	350°C	400°C	450°C	500°C	550°C	600°C	650°C
40	40	40	35	30	30	25	25
45	45	40	40	35	30	30	25
50	50	45	40	40	35	30	30
55	55	50	45	40	35	35	30
60	60	55	45	45	40	35	35
65	-	55	50	45	40	40	35
70	-	60	55	50	45	40	40
75	-	-	55	50	45	45	40
80	-	-	60	55	50	45	40
85	-	-	-	55	50	50	45
90	-	-	-	60	55	50	45
95	-	-	-	-	55	55	50
100	-	-	-	-	60	55	50
105	-	-	-	-	60	55	55
110	-	-	-	-	-	60	55
115	-	-	-	-	-	60	55
120	-	-	-	-	-	-	60
125	-	-	-	-	-	-	60
130	-	-	-	-	-	-	-
135	-	-	-	-	-	-	-
140	-	-	-	-	-	-	-
145	-	-	-	-	-	-	-
150	-	-	-	-	-	-	-
155	-	-	-	-	-	-	-
160	-	-	-	-	-	-	-
165	-	-	-	-	-	-	-
170	-	-	-	-	-	-	-
175	-	-	-	-	-	-	-
180	-	-	-	-	-	-	-
185	-	-	-	-	-	-	-
190	-	-	-	-	-	-	-
195	-	-	-	-	-	-	-
200	-	-	-	-	-	-	-
205	-	-	-	-	-	-	-
210	-	-	-	-	-	-	-
215	-	-	-	-	-	-	-
220	-	-	-	-	-	-	-
225	-	-	-	-	-	-	-
230	-	-	-	-	-	-	-
235	-	-	-	-	-	-	-
240	-	-	-	-	-	-	-
245	-	-	-	-	-	-	-
250	-	-	-	-	-	-	-
255	-	-	-	-	-	-	-
260	-	-	-	-	-	-	-
265	-	-	-	-	-	-	-
270	-	-	-	-	-	-	-
275	-	-	-	-	-	-	-
280	-	-	-	-	-	-	-
285	-	-	-	-	-	-	-
290	-	-	-	-	-	-	-
295	-	-	-	-	-	-	-
300	-	-	-	-	-	-	-
330	-	-	-	-	-	-	-
400	-	-	-	-	-	-	-

Our production plants

Thanks to our modernised and automated production plants in Skamol Branden and Skamol Opole, our technical insulation systems have achieved a unique quality level in terms of stability and characteristics. Not only has this led to a high and consistent quality, but also to an efficient processing of standardised solutions and fast delivery times.

One of the most significant advantages of our calcium silicate boards is that they are extremely light and do not break under extreme temperatures or severe temperature fluctuations.

Boards for versatile applications

The main product in our calcium silicate plants are boards, which can be used for a variety of insulation tasks. This includes, for example, the industrial high-temperature

insulation, the passive fire protection, mould prevention and fireplace cladding.

In addition to boards from bulk production, our customers can also order customised sizes in larger amounts. We are also able to conduct production tests and inspections on a small scale, to ensure an efficient production process for our customers, before commencing large-scale production.

The calcium silicate boards are either delivered to Skamol Roedding for further processing or sent directly to the customers as bulk deliveries, who can then perform the subsequent processing themselves.

All in  one



See more at www.skamol.com